

McCROMETER Propeller Flowmeters

Manual for

Installation, Operation & Maintenance

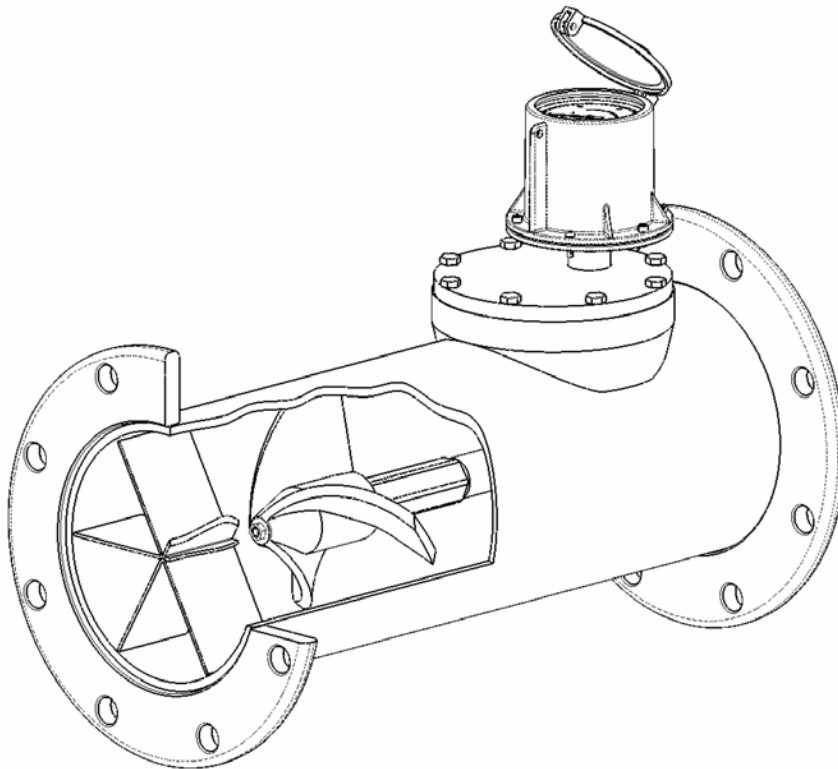

3255 W. Stetson Ave., Hemet, CA 92545

TEL: (951) 652-6811

FAX: (951) 652-3078

Website: www.mccrometer.com

TABLE OF CONTENTS

HOW TO READ MCCROMETER FLOWMETERS	ii
WARRANTY	ii
INTRODUCTION	1
TYPICAL APPLICATIONS INCLUDE	1
PRINCIPLES OF OPERATION	2
GENERAL SPECIFICATIONS	2
ACCURACY	3
HEADLOSS	3
INSTALLATION INSTRUCTIONS	4
OTHER INSTALLATION CONSIDERATIONS	5
SAFETY	5
METER CONSTRUCTION	6
PROPELLER	7
BEARING ASSEMBLY	8
DRIVE ASSEMBLY	8
METERHEAD	9
MAINTENANCE AND TROUBLESHOOTING	10
OCCASIONAL INSPECTIONS	10
TOOLS LIST	10
DISASSEMBLY AND INSPECTION PROCEDURE	11
ORDERING REPLACEMENT PARTS	12
REASSEMBLY PROCEDURE	12
TECHNICAL SUPPORT	13
DRAWINGS	14

HOW TO READ McCROMETER FLOWMETERS

The following guidelines should be helpful for reading totalizers on McCrometer propeller flowmeters:

Most totalizers have “multipliers”. Multipliers are always some multiple or fraction of ten. They are numbers by which we multiply the direct reading of the totalizer. For example, an eight inch meter that totalizes in gallons will have a multiplier of times 100, see figure A. That means that the last digit on the right of the six digit totalizer is not gallons, but hundreds of gallons. In this example, the correct reading is 500 gallons.

The same eight inch meter totalizing in acre feet will have a multiplier of 0.001, see figure B. In this case, “X .001” is printed below the totalizer. The three digit counters on the right side are colored yellow to indicate a decimal point should be placed between the third and fourth digit when reading the totalizer. In this example, the correct reading is 5.555 Acre Feet.

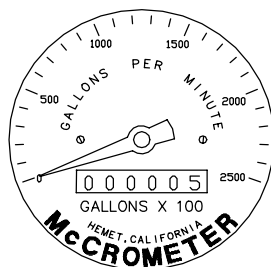

Fig. A

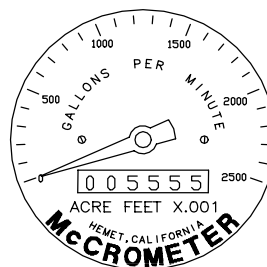

Fig. B

A person reading a totalizer must be careful to add the correct amount of zeroes or place the decimal point in the right place. If a mistake is made, the meter reading can be off by a factor of 10, 100, or even 1000 units.

WARRANTY

This Warranty shall apply to and be limited to the original purchaser consumer of any McCrometer product. Meters or instruments defective because of faulty material or workmanship will be repaired or replaced, at the option of McCrometer Inc., free of charge, FOB the factory in Hemet, California, within a period of one (1) year from the date of delivery.

Repairs or modifications by others than McCrometer Inc. or their authorized representatives shall render this Warranty null and void in the event that factory examination reveals that such repair or modification was detrimental to the meter or instrument. Any deviations from the factory calibration require notification in writing to McCrometer Inc. of such recalibrations or this Warranty shall be voided.

In case of a claim under this Warranty, the claimant is instructed to contact McCrometer Inc., 3255 W. Stetson Ave., Hemet, California 92545, and to provide an identification or description of the meter or instrument, the date of delivery, and the nature of the problem.

The Warranty provided above is the only Warranty made by McCrometer Inc. with respect to its products or any parts thereof and is made expressly in lieu of any other warranties, by course of dealing, usages of trade or otherwise, expressed or implied, including but not limited to any implied warranties of fitness for any particular purpose or of merchantability under the uniform commercial code. It is agreed this Warranty is in lieu of and buyer hereby waives all other warranties, guarantees or liabilities arising by law or otherwise. Seller shall not incur any other obligations or liabilities or be liable to buyer, or any customer of buyer for any anticipated or lost profits, incidental or consequential damages, or any other losses or expenses incurred by reason of the purchase, installation, repair, use or misuse by buyer or third parties of its products (including any parts repaired or replaced); and seller does not authorize any person to assume for seller any other liability in connection with the products or parts thereof. This Warranty cannot be extended, altered or varied except by a written instrument signed by seller and buyer.

This Warranty gives you specific legal rights, and you may also have other rights which vary from state to state.

McCrometer Inc. reserves the right to make improvements and repairs on product components which are beyond the Warranty period at the manufacturer's option and expense, without obligation to renew the expired Warranty on the components or on the entire unit. Due to the rapid advancement of meter design technology, McCrometer Inc. reserves the right to make improvements in design and material without prior notice to the trade.

All sales and all agreement in relation to sales shall be deemed made at the manufacturer's place of business in Hemet, California and any dispute arising from any sale or agreement shall be interpreted under the laws of the State of California

PROPELLER FLOWMETERS

INTRODUCTION

Propeller flowmeters are widely accepted as a proven technology for measuring flow with high accuracy and excellent repeatability. McCrometer Inc. produces propeller flowmeters used around the world for agricultural, municipal, and industrial applications.

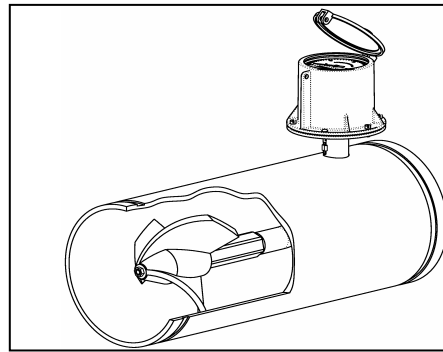
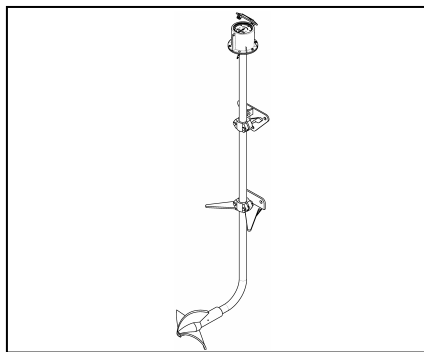
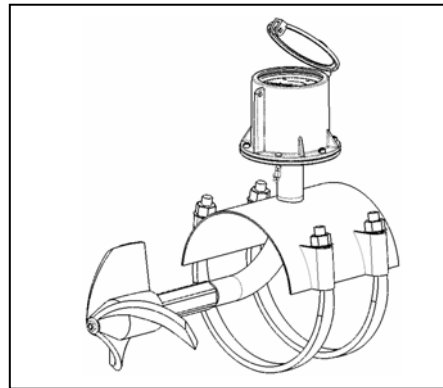
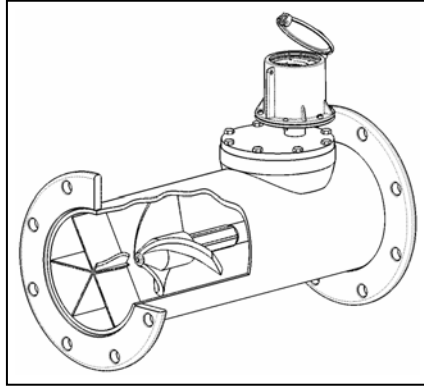

TYPICAL APPLICATIONS INCLUDE

- Drip irrigation systems
- Plant effluent
- Sprinkler irrigation systems
- Raw water intake
- Center pivot systems
- Hot water & petroleum mixtures
- Farm turnouts from irrigation districts
- Process batching & chemical feed
- Golf course and park management
- Remote indication, totalizing, & recording
- Commercial nurseries
- Multi-stage pump actuation and control
- Valve actuation and control
- Return activated sludge
- Water and wastewater management

PRINCIPLES OF OPERATION

The measuring element of a propeller flowmeter consists of a rotating device, called a rotor or propeller. Positioned in the center of the flowstream, the propeller rotates at a rate proportional to the velocity of the fluid through the flowmeter. This rotation can be transmitted mechanically to a register assembly and the fluid's volumetric flowrate and accumulated volume can then be displayed.

GENERAL SPECIFICATIONS

SIZES AVAILABLE	2" to 96"
FLOWRATES AVAILABLE	40 to 75,000 GPM
TURNDOWN	up to 15:1
ACCURACY	±2%
REPEATABILITY	±0.25%
RATED PRESSURE	150 PSI
RATED TEMPERATURE	160 °F

DESCRIPTIONS:

- **TURNDOWN:** Propeller meters are specified to work within a certain range of flowrates. Turndown is the ratio of the maximum flowrate to the minimum flowrate of the meter. A typical turndown of an 8" meter is 15:1. (e.g., max. flow = 1500 gpm to min. flow = 100 gpm)
- **ACCURACY:** Accuracy shows how close the measurement of the meter is to the actual flow in the pipe. Within its turndown (described above), the reading of the meter is guaranteed to be ±2% of the actual flow.
- **REPEATABILITY:** Flowmeter repeatability is the ability of a meter to reproduce a measurement under similar conditions. This is not by itself a measure of accuracy, but rather a component of the meter's total accuracy. McCrometer propeller meters have a repeatability of ±0.25%.
- **PRESSURE:** The pressure rating for standard propeller meters is 150 PSI. This pressure rating refers to the constant line pressure in the pipe. Some models can be rated up to 300 PSI. Higher pressures are available on special request.
- **TEMPERATURE:** The temperature rating for standard propeller meters is 160 °F constant temperature. This temperature rating refers to fluid temperature. Most standard models can be upgraded to 180° F constant temperature on special request.

ACCURACY

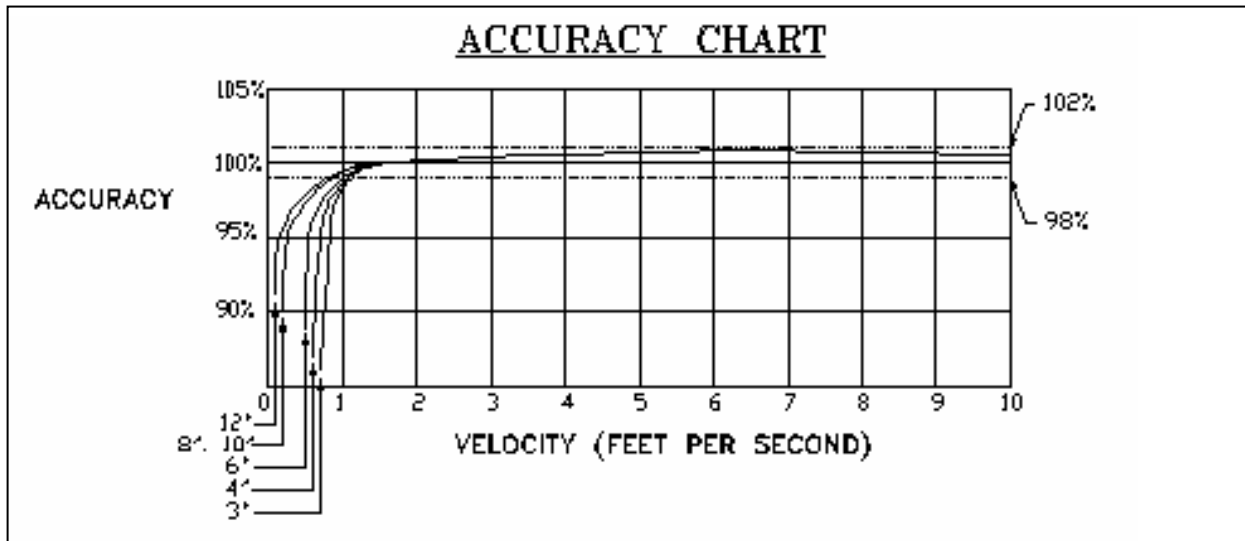

Standard flowrates for McCrometer propeller meters are shown below. Readings are guaranteed accurate within $\pm 2\%$ in these flowrates. Please note that over 80 percent of the meter's flow range, the accuracy is better than $\pm 1\%$.

Nominal Meter Size	2"	2.5"	3"	4"	6"	8"	10"	12"	14"	16"	18"	20"	24"
Minimum Flow(U.S.GPM)	40	40	40	50	90	100	125	150	250	275	400	475	700
Maximum Flow(U.S.GPM)	250	250	250	600	1200	1500	1800	2500	3000	4000	5000	6000	8500

HEADLOSS

Headloss refers to the fluid pressure lost due to the meter. Propeller meters have very low permanent headloss as seen in the chart below

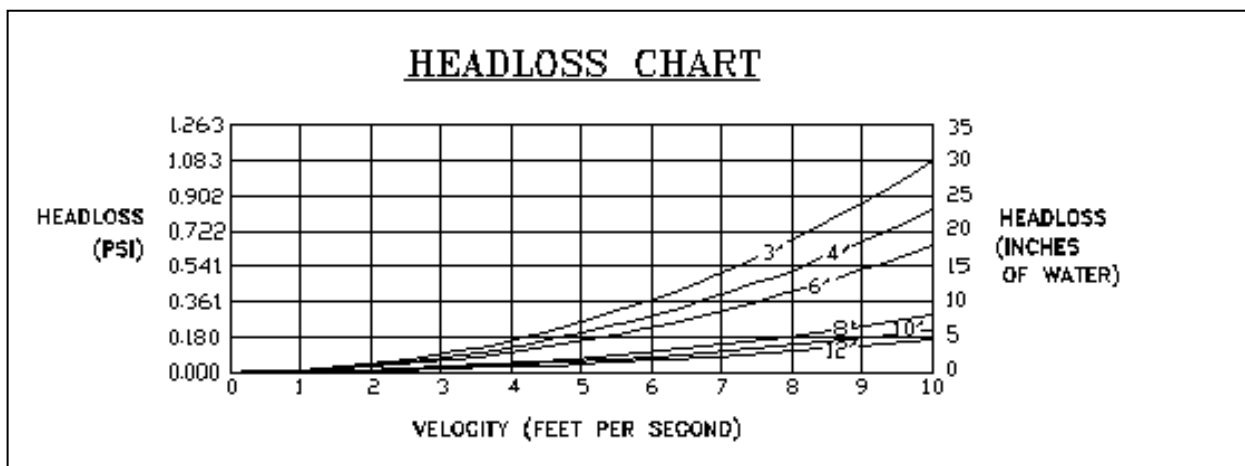

Nominal Meter Size	3"	4"	6"	8"	10"	12"	14"	16"	18"	20"	24"
Max. Headloss (in. H ₂ O column)	30	23	17	7	4	3	2	2	2	1	1

INSTALLATION INSTRUCTIONS

Proper meter installation is the first step to ensure excellent meter performance. Follow these instructions closely. Consult an authorized service representative or the factory for any circumstances encountered which are not covered in this manual.

All McCrometer products are tested and inspected during manufacture and prior to shipping. An inspection should be performed at the time of unpacking to detect any damage that might have occurred during shipment.

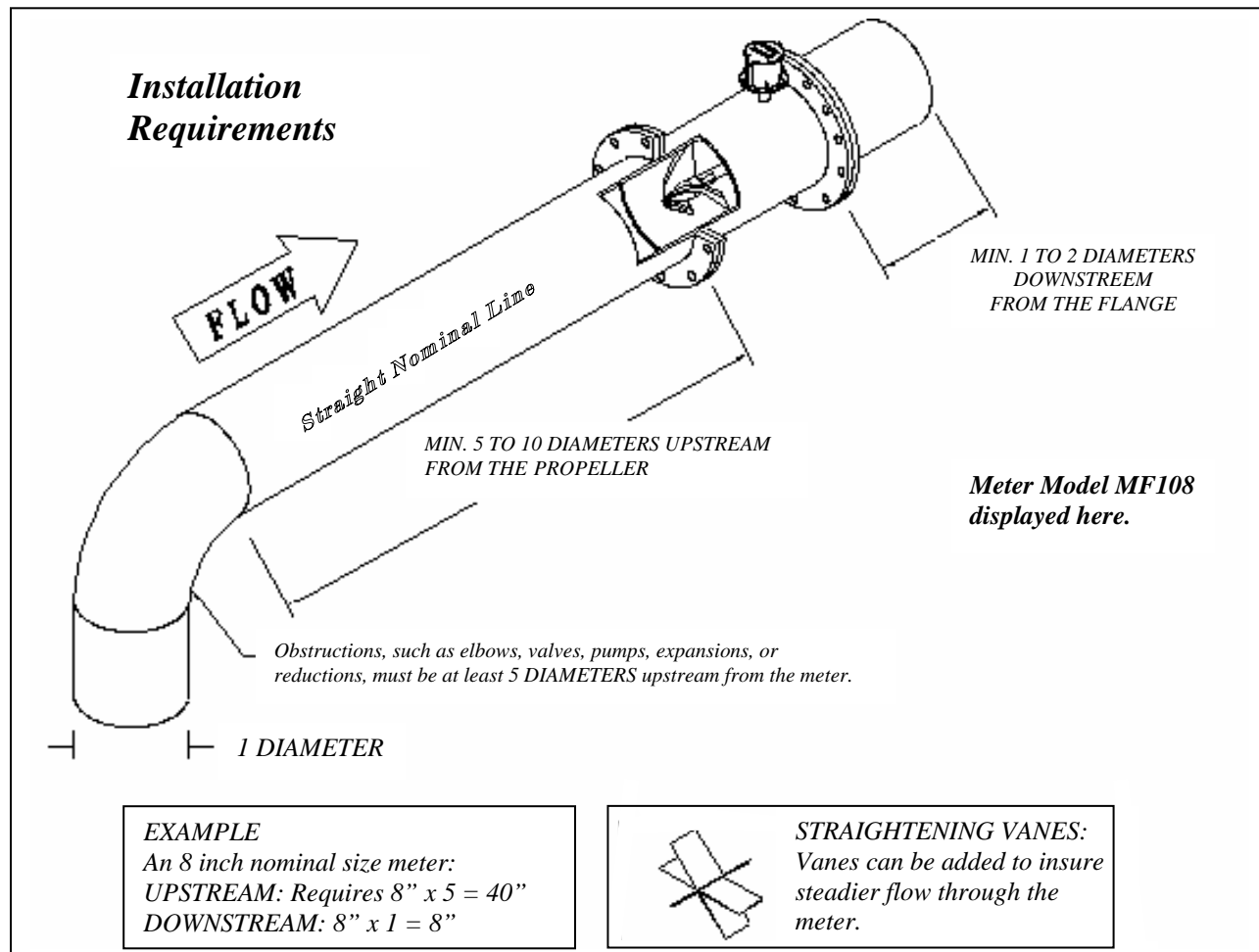

Installation requirements

Fig. 1

McCrometer propeller meters should be installed a minimum of five to ten diameters downstream of any obstructions. The exact upstream and downstream piping requirements are specific to the meter model number. For upstream and downstream piping requirements relating to your specific meter, contact the factory for assistance at 951/652-6811 ext. 215. (Please be prepared to provide the serial number of your meter.) Flowmeters are velocity sensing devices and are vulnerable to certain upstream disturbances. Because of this, meters need certain lengths of straight pipe runs before and after the meter. These distances usually relate to the diameter of the pipe used. Obstructions can include elbows, valves, pumps, and changes in pipe diameter. The uneven flow created by these obstructions can vary with each system. If your application provides for more than five diameters of upstream run, use the available distance.

Downstream run should be one to two diameters of straight pipe length after the meter.

NOTE: Special attention should be given to systems using two elbows “out of plane” or devices such as a centrifugal sand separator. These cause swirling flow in the line that affect propeller meters. Well developed swirls can travel up to 100 diameters downstream if unobstructed. Since most installations have less than 100 diameters to work with, straightening vanes become necessary to alleviate the problem. Straightening vanes will break up most swirls and ensure more accurate measurement. McCrometer’s mainline meters like the MW500 series have vanes included as a standard feature. If your model does not have straightening vanes (e.g., M0300 Bolt-On Saddle series), McCrometer actively encourages you to include them in the pipe just ahead of the meter.

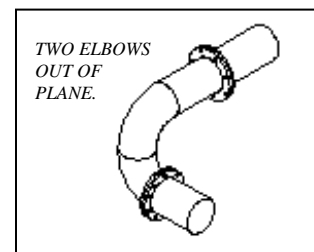

OTHER INSTALLATION CONSIDERATIONS

- All propeller flowmeters are calibrated for a full pipeline. If the pipe is not completely full, the flowmeter will over register the flow. Although a minimum line pressure is not necessary for an accurate measurement, a full pipe is necessary.
- McCrometer flowmeters can be mounted either horizontally or vertically. Although most applications are horizontally oriented, mounting the meter vertically actually offers some slight advantages. One reason is that gravity has a more pronounced flow conditioning effect with lines in the vertical (as opposed to horizontal) orientation. McCrometer flowmeters are calibrated for horizontal installation. If the meter is to be mounted vertically, please notify the factory at time of order.
- With the meter installed, check the rate-of-flow indicator. It should be stable to the point that it can be easily read. Some movement is normal, but if the indicator is moving erratically back and forth, disturbances exist and meter accuracy decreases. If you suspect a problem, please refer to the **INSTALLATION INSTRUCTIONS** section or the **MAINTENANCE AND TROUBLESHOOTING** section.

SAFETY

- Any person installing, inspecting, or maintaining a McCrometer flowmeter should have a working understanding of piping configurations and systems under pressure.
 - Before adjusting or removing any meter, be certain the system has depressurized completely. **NEVER ATTEMPT TO REMOVE A METER UNDER PRESSURE!**
 - Be careful when lifting meters. Meters can cause serious injury if lifted incorrectly or dropped.
 - Only necessary and appropriate tools should be used when working on a meter. For tools list see page 10.
 - Before starting a system, make sure all connections are properly secured. Keep a safe and prudent distance away from the meter during system start-up.
-

METER CONSTRUCTION

Every McCrometer propeller meter is constructed and assembled at the McCrometer factory. Each part of your meter has been refined and improved over thirty years. Quality assurance at each step of the production process ensures every meter to be accurate and reliable for years of service.

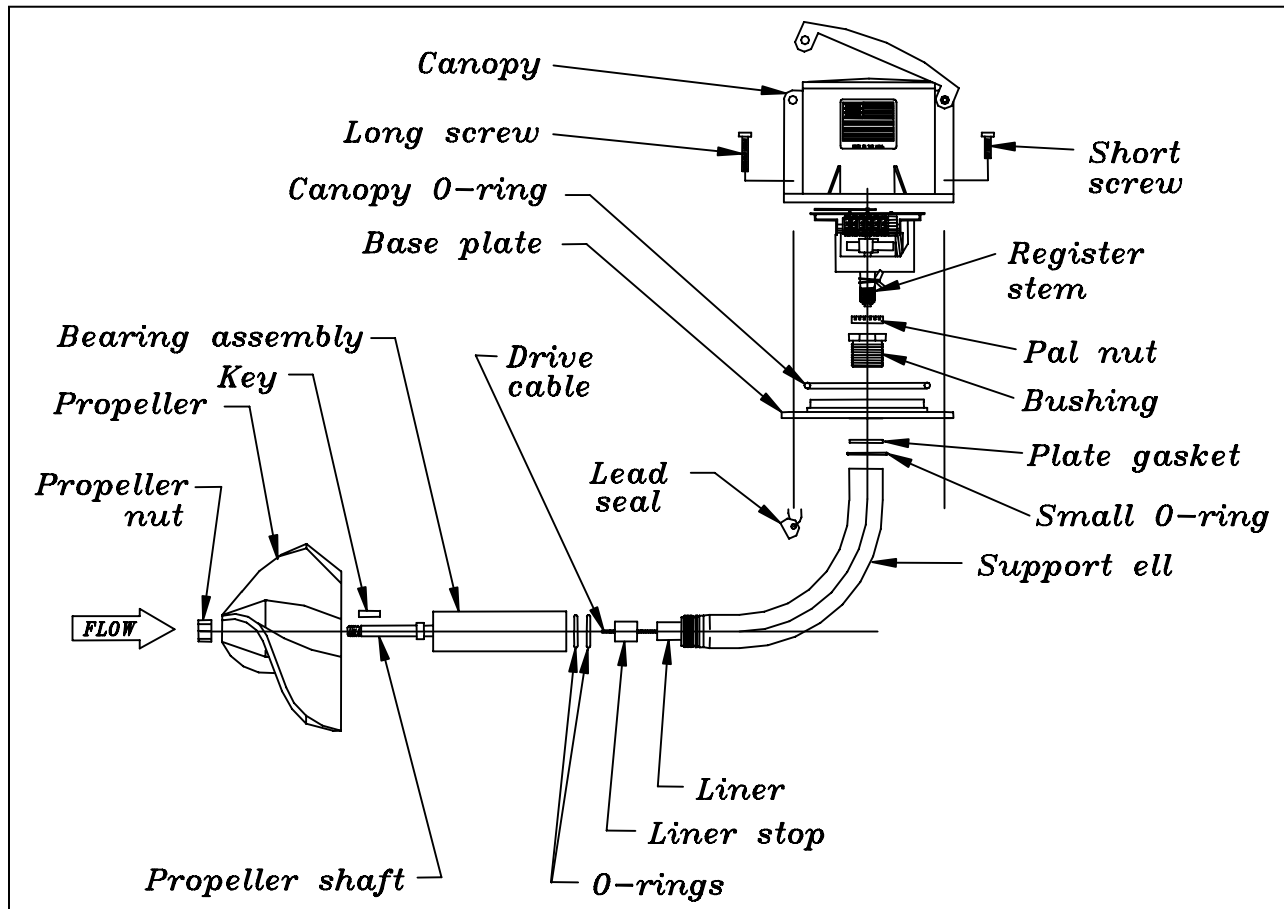

Basic meter element assembly Fig. 2

McCrometer propeller meters have a simple design with a limited number of moving parts. Figure 2 shows labeled parts that are commonly shared among models. Though different models may look somewhat different than the model shown above, each shares certain components. These components are described in detail on the following pages.

PROPELLER

The propeller is, of course, a most important part of any propeller meter.

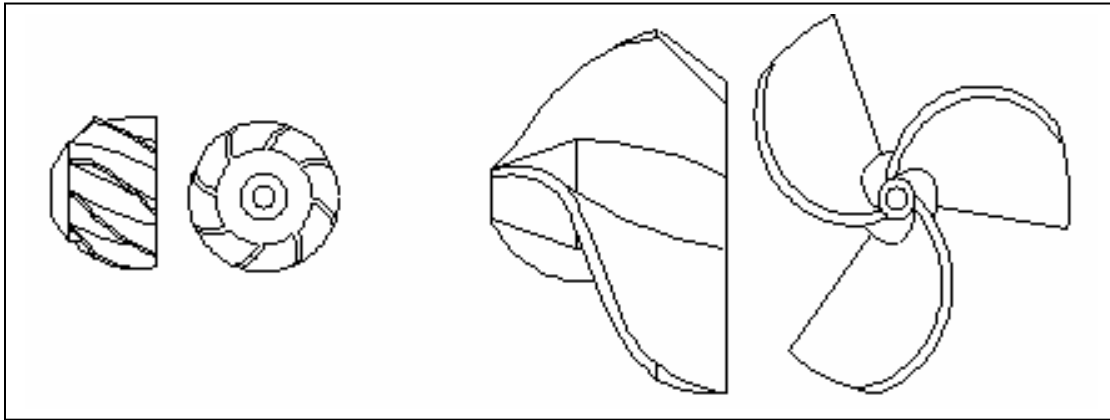

Eight and Three Blade Propellers Fig. 3

McCrometer propellers have the following characteristics that ensure accurate readings:

- Each propeller is wet calibrated in a NIST (National Institute of Standards and Technology) traceable laboratory and trimmed so that a standard ratio is achieved. This allows for easy parts replacement in the field without recalibration.
- Propellers have a curved shape called the helical lead. The helical lead governs the rotational speed for a given flow velocity.
- Propellers are as light as possible so that the momentum of the fluid is large in relation to the mass of the propeller. As a result, lower flows can be measured and changes in velocity can be detected more rapidly.
- The propeller is sufficiently rigid to retain its shape during high flow conditions throughout the life of the meter.
- Propellers are large in relationship to the line size. This is necessary to affect the whole flow, which both averages the velocity profile and reduces inaccuracy.
- The propeller covers and protects the bearings to reduce debris and other fluid particles from entering the bearing assembly.

BEARING ASSEMBLY

Two shielded stainless steel bearings support the propeller shaft and allow it to rotate freely. The propeller covers the bearings to help prevent loss of lubrication and entry of foreign particles found in the fluid. For higher than normal flows, a third over-run bearing can be added to the propeller shaft to increase the life of the meter.

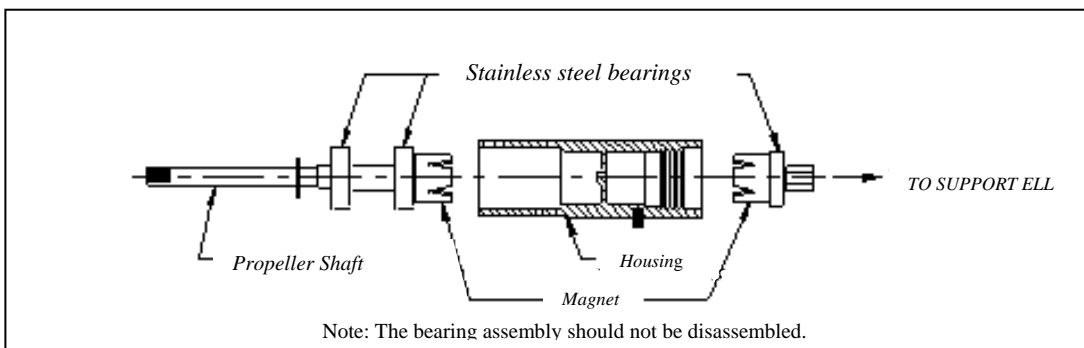

Bearing Assembly

Fig. 4

The bearing assembly housing prevents the process fluid from entering the drive assembly. The housing is manufactured with an integral diaphragm separating the fore and aft sections. Two permanent magnets on either side of the diaphragm transmit the rotation of the propeller through the diaphragm, while preventing fluid from entering the aft chamber. This magnetic drive makes an excellent and frictionless seal. This connection also allows the magnets to slip if a sudden surge hits the propeller. This slippage protects the meterhead from excess torque. The bearing assembly threads onto the drive assembly support and seals with two O-rings.

DRIVE ASSEMBLY

The drive assembly supports the bearing assembly and propeller and transmits propeller revolutions to the meterhead.

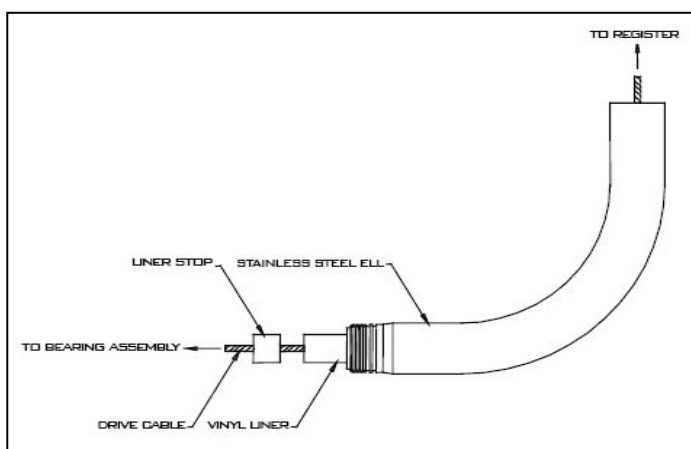

Drive Assembly

Fig. 5

A heavy walled stainless steel pipe cold formed into an ell (90 degree) shape supports both the bearing assembly and the propeller. This ell holds a steel cable encased in a protective vinyl liner. The cable extends outside the liner to attach to the aft of the bearing assembly and the bottom of the meterhead to transmit the revolutions of the propeller to the register.

METERHEAD

The meterhead consists of a register, canopy, and a base plate. The register transforms the speed of the propeller into both a totalizer and an instantaneous flow indicator. McCrometer's totalizers are six-digit, straight-reading type. Units of totalization include many standard units such as gallons, cubic feet, acre feet, and cubic meters.

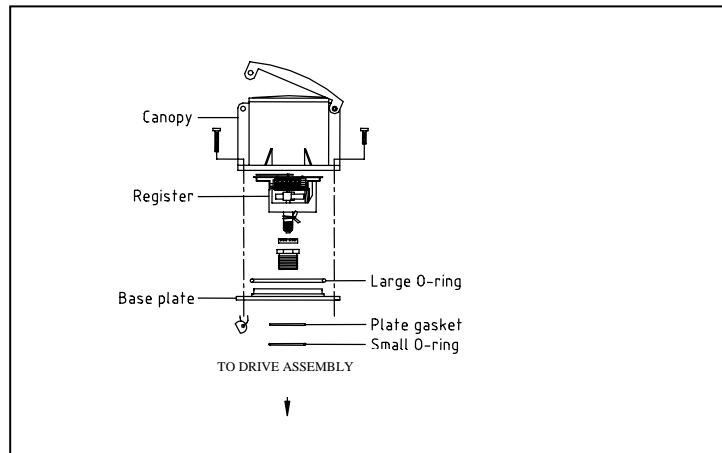

Meterhead

Fig. 6

The instantaneous flow indicator is of the mechanical magnetic cup design. Indicator units include gallons per minute, cubic feet per second, and liters per second, as well as many others. McCrometer offers this instantaneous flow indicator standard.

The entire register threads into a bushing which holds a die cast aluminum base plate to the ell where it connects with the drive cable. The base plate seals to the ell with an O-ring and Gasket. A die cast aluminum canopy covers the register and attaches to the base plate with six screws. A stamped tamper seal attached to one of these screws ensures that the instrumentation of the register remains unaltered.

UNDERSTANDING THE REGISTER GEAR RATIO:

Each register has a gear ratio that is matched to the propeller. For instance, consider an 8" McCrometer meter totalizing in gallons. A standard 8" meter will have a gear ratio of 400:1,

which means the propeller must rotate 400 times for the first odometer wheel to turn one complete revolution. This first odometer wheel usually symbolizes a certain multiple of the totalizing units, called a multiplier. Since the totalizer on the 8" meter has a multiplier of times 100 (signified by two zeros to the right of the odometer wheels), each number on the first odometer wheel represents one hundred gallons. Therefore, one complete rotation of the first odometer wheel is ten times one hundred gallons, or

1000 gallons. So remembering the gear ratio for this example is 400 propeller revolutions to one full turn of the odometer wheel, 400 propeller revolutions equals 1000 gallons.

Example: Standard 8" meter: 400 propeller rev. = 1 rev. of odometer wheel = 1000 gallons

NOTE Each line size has its own gear ratio. Registers from different size meters cannot be interchanged freely.

Be sure you know your meter's gear ratio and multiplier for reference.

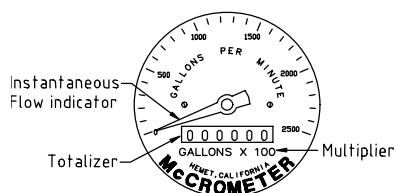

MAINTENANCE AND TROUBLESHOOTING

McCrometer Inc. manufactures propeller meters to be as trouble free as possible. The first criteria in a successful meter application is that the meter is installed correctly. Please refer to the earlier Installation Instructions or call an authorized service representative or the factory to answer any questions.

OCCASIONAL INSPECTIONS

Our flowmeters commonly operate for years with little or no routine maintenance. Occasional inspections should be conducted to listen and look for signs of mechanical wear and breakage.

- McCrometer flowmeters operate very quietly and any grinding or growling noises that can be detected are the first signs that mechanical failure is near.
- Visual cues are also valuable indicators. A once steady rate-of-flow indicator that has become erratic is usually indicative of something beginning to fail. Fogging seen through the lens would suggest a leak, either from the bearing assembly, or from an external seal.
- If there is doubt whether your rate of flow indicator is properly functioning, perform this simple test. Bring the flow through the meter to a relatively high, steady rate. Time a specific increment of the totalizer wheel. Each meter will require different but simple calculations to determine if your rate of flow indicator agrees with your totalizer.

At the first sign of trouble, the system should be shut down and the meter removed for inspection.

TOOLS LIST

The following list includes tools needed to service and maintain McCrometer propeller meters:

- Open or box end wrenches for top plate bolts (these vary with line size):
 - 1/2" for 2", 2 1/2", and 3" line sizes
 - 9/16" for 4", 6", and 8" line sizes
 - 3/4" for 10" and 12" line sizes
- Open or box end wrenches in the following sizes:
 - 9/16" for propeller nut
 - 1 3/8" for bearing assembly
 - 15/16" for register pal nut
- 1 3/8" Deep Socket
- Standard, flat screwdriver with 6" reach for canopy screws
- Wire cutters for removing tamper seal
- Hammer
- Small wire brush for cleaning threads
- Clean cloth or rag
- Loctite (Aronite Stock CE-805-Color Blue is suggested)
- Light machine oil

DISASSEMBLY AND INSPECTION PROCEDURE

1. **REMOVE THE METER OR ELEMENT.** Depending on the model, remove the entire meter or the metering element (propeller, bearing and drive assemblies, and meterhead) to access the propeller and bearing assembly.

****WARNING**** Do not remove the meter or top plate under pressure!

2. **CHECK THE PROPELLER.** Check the propeller for broken or damaged blades or foreign material hanging from it. Careful examination should be made of the propeller's trailing edge for damage. Some small nicks and abrasions to the leading edge of the blades are common and will not affect the accuracy of the meter. McCrometer's propeller blades are thick, resulting in a strong, stiff blade that does not change shape under normal operations.

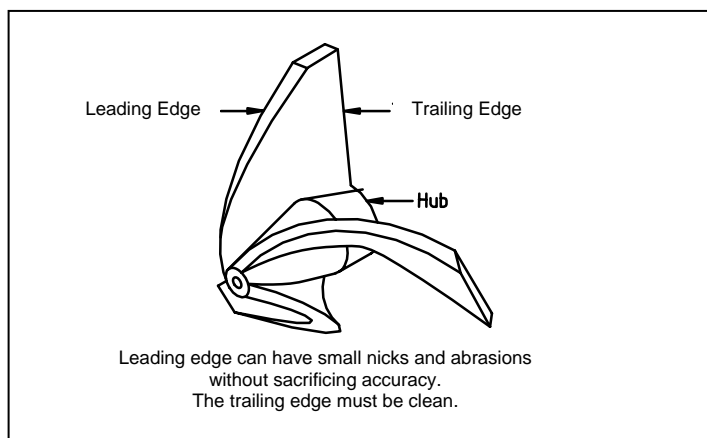

Check for propeller damage

Fig. 7

3. **CHECK THE BEARINGS.** Check the condition of the bearings by grasping the propeller and trying to move it up and down and sideways. If the propeller has any amount of "play," the bearing assembly should be replaced.
4. **REMOVE THE PROPELLER.** Remove the propeller by unscrewing the nut on the end of the propeller with a 9/16" wrench. Pull the propeller off the end of the bearing assembly shaft. Watch for the key, it may remain on the shaft, on the propeller, or fall free. If the propeller will not come off by hand, lightly tap the hub of the propeller with a hammer. Tap only the hub, since striking the trailing edge of the propeller blade may change the calibration of the meter. One or more stainless steel washers may be on the shaft. Leave these in place.
5. **REMOVE THE BEARING ASSEMBLY.** Remove the bearing assembly by unscrewing it with a 1 3/8" wrench. The drive cable may come out at this time. Set it aside for now. A deep 1-3/8" socket will be required for meters with fixed ells. After removing the bearing assembly, hold the shaft and spin the bearing housing. It should spin freely and smoothly. If it does not, it should be replaced.
6. **CHECK.** Check for damaged threads and clean the O-ring grooves.

7. REMOVE THE DRIVE CABLE. Now pull the drive cable out of the ell and inspect it for moisture, rust, wear, cracks, or breaks. If a cable appears worn, this is usually a symptom of another problem, such as moisture.
8. REMOVE THE REGISTER CANOPY. Remove the register canopy by unscrewing the five short screws and the one long screw with the tamper seal from around the base. Inspect the canopy and the base plate for signs of leaks.

****IMPORTANT**** Removing the tamper seal from a meter that is still under warranty could void the factory warranty.

9. REMOVE THE REGISTER HEAD. Remove the register head by loosening the pal nut on the stem of the register with a 15/16" wrench. Unscrew the whole register unit. Inspect the register for moisture. Look for a white chalky substance on the frame of the register that shows the register was wet. Turn the very bottom of the register stem several times. The register movement should turn freely. The first odometer wheel also should turn. If not, the register should be returned for repair or exchange. The purpose of the silica gel dry pack is to absorb moisture trapped during assembly. Replace the silica pack.
10. REMOVE THE CABLE LINER. If moisture exists inside the drive assembly, the liner should be taken out to dry. To remove the liner, use an item such as a large bolt to tap the liner down from the top. Tap enough to push the liner stop out from the bottom to allow the liner to be pulled free.

ORDERING REPLACEMENT PARTS

When ordering replacement parts, the meter's serial number is needed to ensure correct replacements. The serial number can be found on the register canopy lid. The number sequence should look similar to: 94-789-8. The first two digits are the year of manufacture, the second set of digits is the number of the meter, and the last set of digits is nominal line size. For meters manufactured before 1994, the last sets of digits are reversed.

For specific meter part numbers, see the drawings that follow.

REASSEMBLY PROCEDURE

Now, with the problem found and the correct replacement parts collected, the meter must be correctly reassembled to ensure trouble-free service in the future.

1. CLEAN ALL PARTS. As with any mechanical device, all of the parts that are going to be reused must be clean and free of dust and dirt. Take some time and make sure these parts are ready to be used.
2. REPLACE THE CABLE LINER. If the cable liner was removed, replace it now. Push the cable liner into the ell from the bottom up to the base plate. Replace the liner stop.
3. CLEAN THE LINER. Blow out any dirt that may be trapped inside the liner.
4. REPLACE THE BEARING ASSEMBLY. With a drop of light machine oil on your finger, lubricate the small O-rings on the end of the threaded ell. (Do not get oil on the threads of ell.) Place two drops of Loctite on the threads of the ell.

Thread the bearing assembly on the ell and tighten with a wrench or a special bearing tool. Be careful not to cross thread the assembly and only snug the bearing assembly with the wrench. Extra care should be exercised in assuring that the parts are clean and the O-rings have a good sealing area.

5. REPLACE THE PROPELLER. Make sure the washers on the propeller shaft are in

****IMPORTANT**** Use only two drops of Loctite. Too much Loctite can cause the aft bearing to seize.

place. Slide the propeller over the shaft. Align the shaft and propeller key ways and insert the key. You may need to use a screw driver to push the key to the fully engaged position. Apply a small amount of Loctite to the threads of the nut and tighten to a good snug fit, but not as tight as possible.

6. REPLACE THE DRIVE CABLE. With a clean cloth, wipe off any dirt or dust from the drive cable. Apply a small amount of light machine oil to the cable and insert it all the way into the ell. To engage the cable, slowly turn the propeller as you gently push on the cable. After you are satisfied that the cable is in the bearing assembly as far as possible, check the height of the cable in relationship to the top of the mounting plate bushing. The cable should be within 1/4 of an inch (plus or minus) from the top of the bushing. If not, it is the wrong cable or the cable is not fully into the bearing assembly.
7. REPLACE THE REGISTER HEAD. Thread the pal nut, with the open face up, onto the stem on the bottom of the register. The nut should be at least halfway up the threads. Place the register stem on the drive cable and screw it into the mounting plate bushing. The register should be screwed down far enough that the cable is well into the register stem but not far enough to bind the cable. Face the register the desired direction and tighten the pal nut to lock the register into position.
8. CHECK. Spin the propeller to check that the rate of flow indicator and totalizer are engaged. Listen for any clicking or grinding noises. The meter should turn quietly.
9. REPLACE THE REGISTER CANOPY. Install the large O-Ring and flat gasket onto the base plate. Use a small amount of light oil to lubricate the O-Ring and place the register canopy down over it. Push down until the O-Ring bottoms out against the base plate. Replace the six screws and lightly snug them.
10. RE-INSTALL THE FLOWMETER. Re-install the flowmeter. Before pressurizing the system, make sure all connections are properly secured. As an obvious general safety consideration, maintain a safe and prudent distance from the meter when the system is to be started. After the system restarts, the indicator should be smooth and the meter quiet.

TECHNICAL SUPPORT

For technical assistance, please contact your authorized service representative or the factory at:

McCrometer Inc.

3255 W. Stetson Avenue

Hemet, CA 92545

PHONE: (951) 652-6811 FAX: (951) 652-3078

Hours: 8 a.m. - 4 p.m. PT, Mon-Fri

MF100 MG100 MS100 MT100



DESC 2", 2-1/2", & 3" FIXED ELL METERS

FILE: 24517-11-01.dwg

BY CEH DATE 9-28-1993 APP EDM DATE 4-6-2007

NOTES:

1. XX DEPENDS ON SPECIFIC REQUIREMENT
2. DRAWING IS NOT SHOWN TO SCALE.

1 2 3 4 5 6

NOMINAL SIZE	REGISTER	BEARING	PROPELLER	LINER	CABLE	LINER STOP
2", 2-1/2", 3"	R1103-XX	B0700-XX	P0103-XX	6.75"	D0103-00	D0370-10

PLEASE HAVE THE METER SERIAL NUMBER WHEN ORDERING REPLACEMENT PARTS

3-PIECE SUPPORT REPLACEMENT COMPONENTS

4 5 6

NOMINAL SIZE	LINER	CABLE	LINER STOP
2", 2-1/2", 3"	5.31"	D0066-00	D0370-00

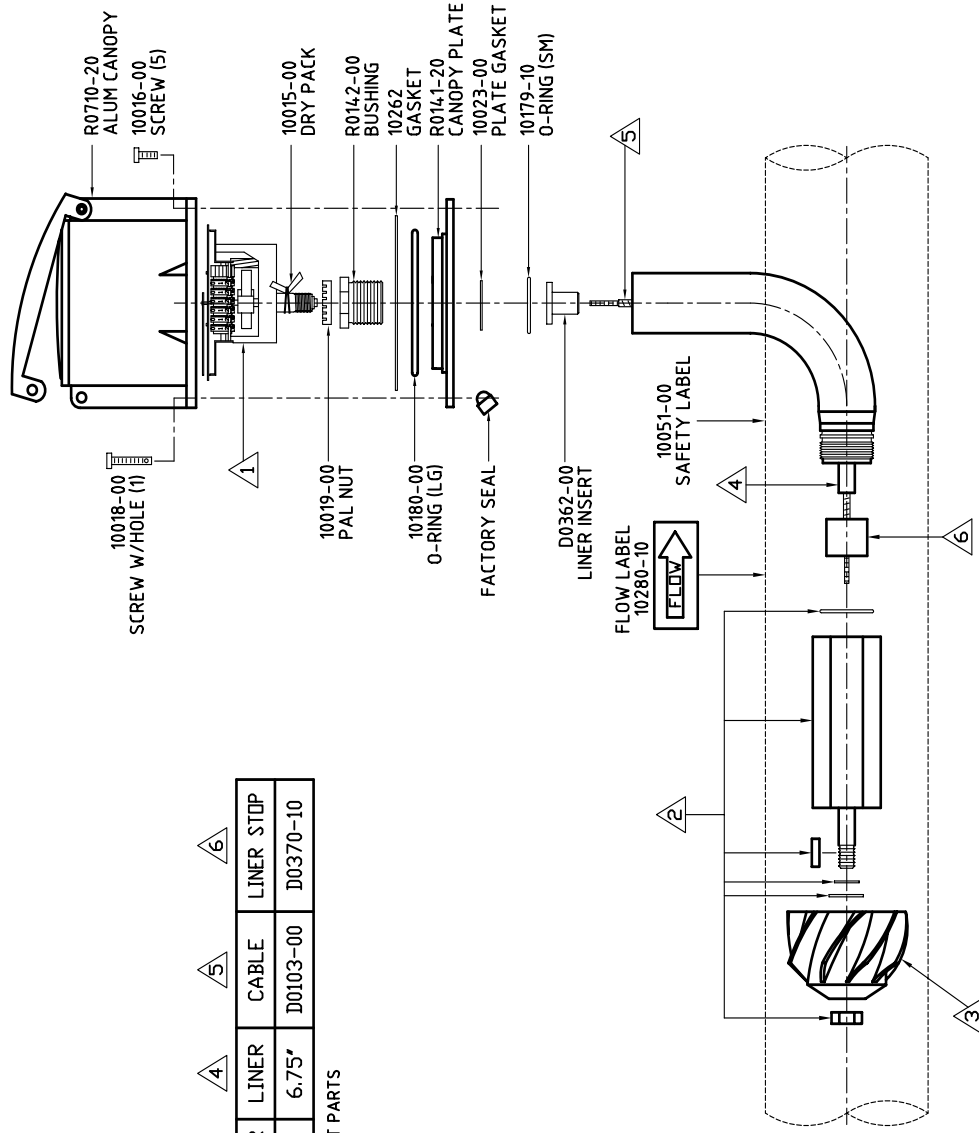



MF100 MZ100 MZ200 MG100 MS100 MT104 MT106

4" THRU 24" FIXED ELL METERS

DESC BY CEH DATE 9-24-1993 APP EDM DATE 4-9-2007

FILE: 24517-11-02.dwg

NOTES:
 1. XX DEPENDS ON SPECIFIC REQUIREMENT
 2. DRAWING IS NOT SHOWN TO SCALE.

MG100 MS100 MT104 & MT106 MF100 MZ100 MZ200

SIZE	REGISTER	BEARING	PROPELLER	LINER	CABLE
4"	R1104-XX	B0600-XX	P0104-XX	D0304-00	D0104-00
6"	R1106-XX	B0100-XX	P0106-XX	D0304-00	D0104-00
8"	R1108-XX	B0100-XX	P0108-XX	D0304-00	D0104-00
10"	R1110-XX	B0100-XX	P0110-XX	D0303-00	D0122-00
12"	R1112-XX	B0100-XX	P0112-XX	D0305-00	D0105-00
14"	R1114-XX	B0100-XX	P0112-XX	D0313-00	D0123-00
16"	R1116-XX	B0100-XX	P0112-XX	D0306-00	D0106-00
18"	R1118-XX	B1500-XX	P0116-XX	D0307-00	D0107-00
20"	R1120-XX	B1500-XX	P0116-XX	D0307-00	D0107-00
24"	R1124-XX	B1500-XX	P0116-XX	D0308-00	D0108-00

PLEASE HAVE THE METER SERIAL NUMBER WHEN ORDERING REPLACEMENT PARTS

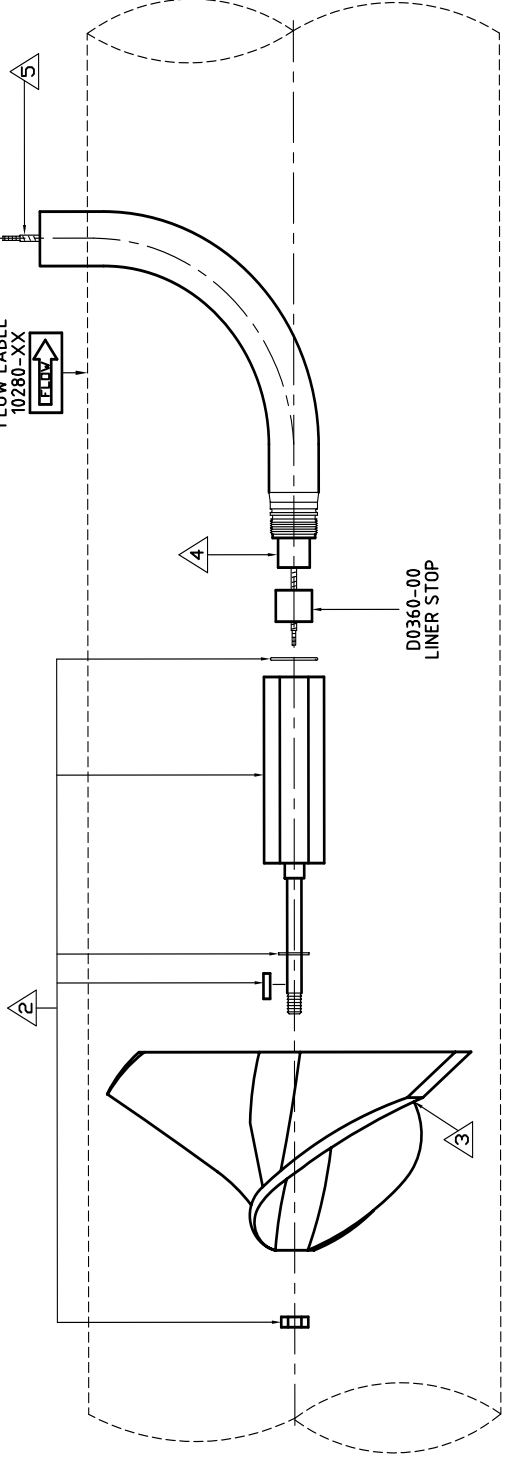
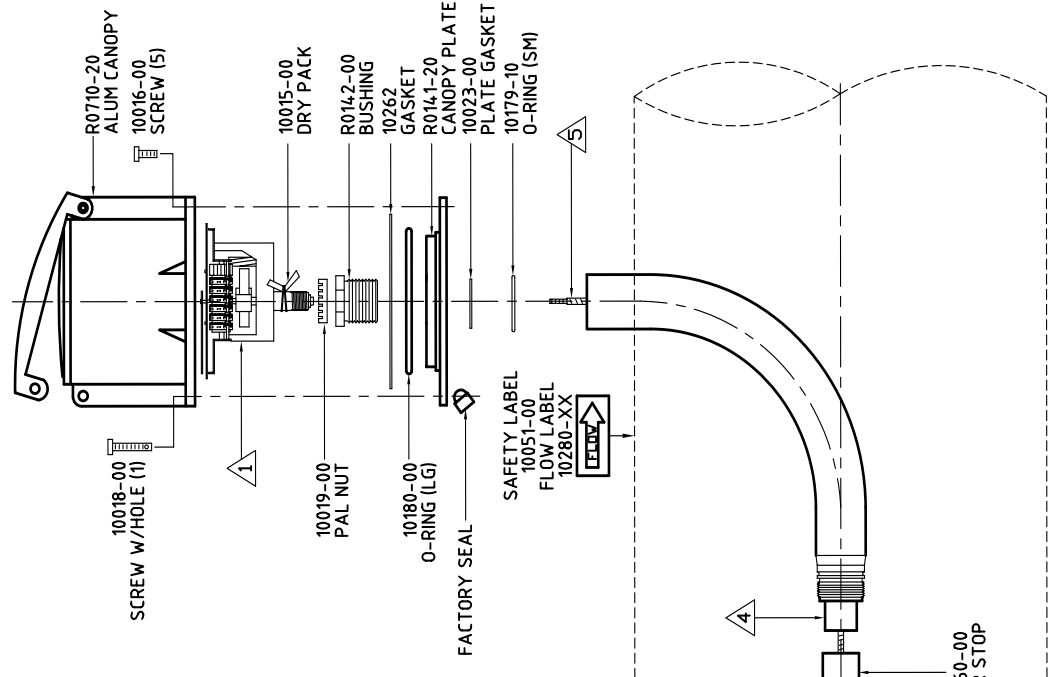

ML100



DESC

4" THRU 24" FIXED ELL FLANGED IRRIGATION METERS

FILE: 24517-11-03.dwg

BY CEH DATE 9-27-1993 APP EDM DATE 4-6-2007

NOTES:

1. XX DEPENDS ON SPECIFIC REQUIREMENT
2. DRAWING IS NOT SHOWN TO SCALE.

SIZE	REGISTER	BEARING	PROPELLER	LINER	CABLE
6"	R1106-XX	B0100-XX	P0106-XX	D0304-00	D0104-00
8"	R1108-XX	B0100-XX	P0108-XX	D0304-00	D0104-00
10"	R1110-XX	B0100-XX	P0110-XX	D0303-00	D0122-00
12"	R1112-XX	B0100-XX	P0112-XX	D0305-00	D0105-00

PLEASE HAVE THE METER SERIAL NUMBER WHEN ORDERING REPLACEMENT PARTS

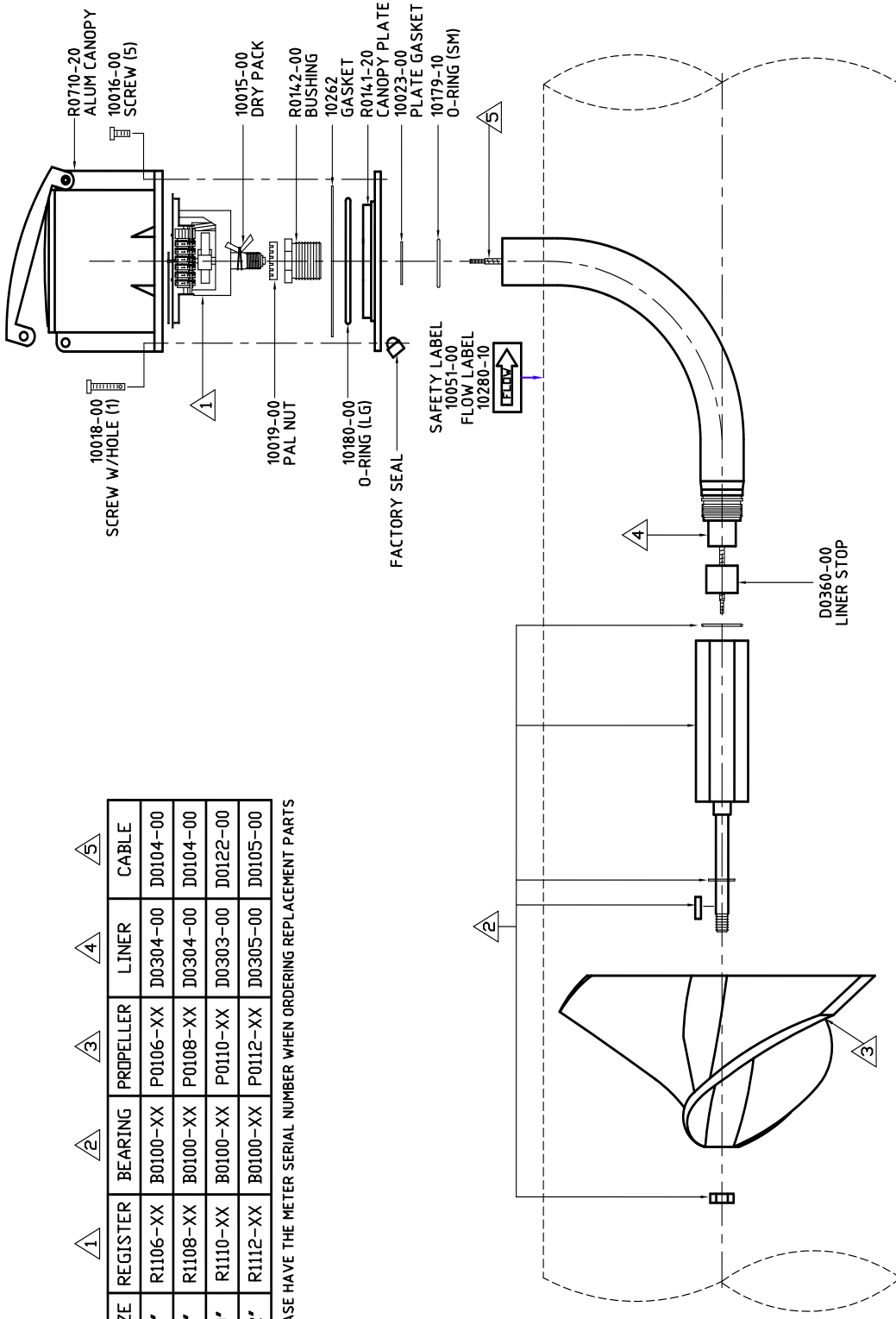

THIS DOCUMENT CONTAINS PROPRIETARY INFORMATION AND MAY NOT BE DISCLOSED TO OTHERS FOR ANY PURPOSE, NOR USED FOR MANUFACTURING PURPOSES WITHOUT WRITTEN PERMISSION FROM MCCROMETER, INC.

REV 3 4-6-2007 JMC

Page 1 of 1

M0300



FILE: MAN M0300

DESC 6" THRU 16" BOLT ON SADDLE METERS

BY CEH DATE 9-23-1993 APP EDM DATE 4-6-2007

NOTES:

1. XX DEPENDS ON SPECIFIC REQUIREMENT
2. DRAWING IS NOT SHOWN TO SCALE.

△ 1 △ 2 △ 3 △ 4 △ 5 △ 6 △ 7

MODEL	REGISTER	BEARING	PROPELLER	LINER	CABLE	U-BOLT/STRAP	GASKET	TEMPLATE
M0306	R1106-XX	B0100-XX	P0106-XX	D0304-00	D0104-00	T0756-00 (2)	T0384-10	10112-03
M0308	R1108-XX	B0100-XX	P0108-XX	D0304-00	D0104-00	T0758-00 (2)	T0384-10	10112-05
M0310	R1110-XX	B0100-XX	P0110-XX	D0303-00	D0122-00	T0760-00 (2)	T0384-11	10112-07
M0312	R1112-XX	B0100-XX	P0112-XX	D0305-00	D0105-00	T0762-00 (2)	T0384-11	10112-09
M0314	R1114-XX	B0100-XX	P0112-XX	D0313-00	D0123-00	T0745-02 (2)	T0384-11	10112-09
M0316	R1116-XX	B0100-XX	P0112-XX	D0313-00	D0123-00	T0740-00 (2)	T0384-11	10112-09

PLEASE HAVE THE METER SERIAL NUMBER WHEN ORDERING REPLACEMENT PARTS

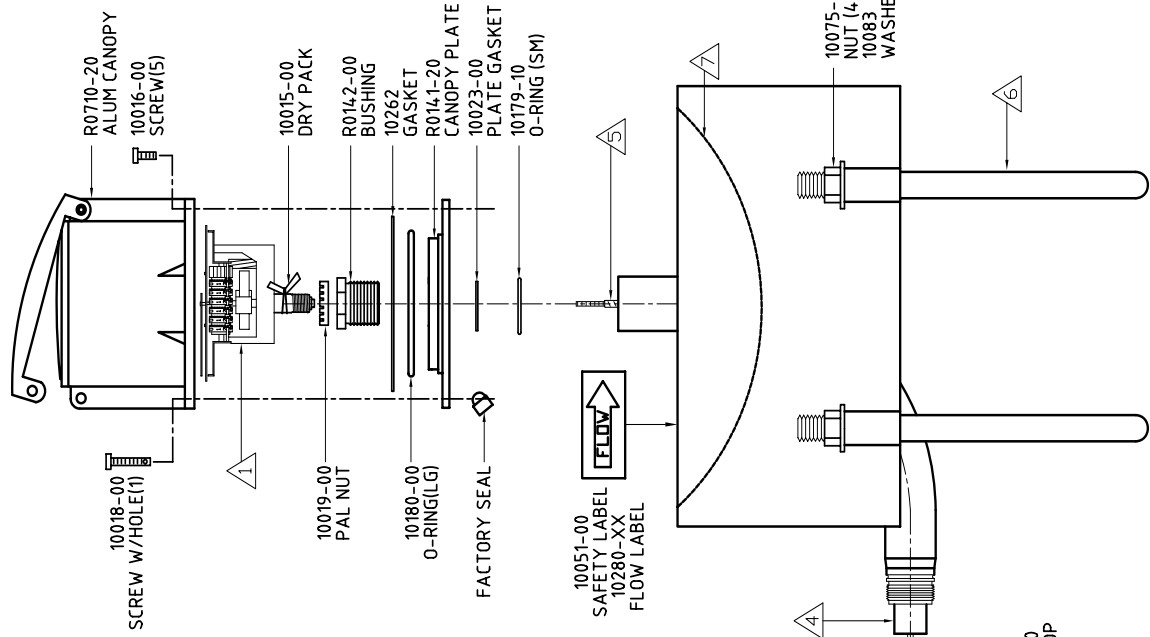

M0304

McCROMETER

FILE: MAN M0304

DESC **4" BOLT ON SADDLE METERS**

BY CEH DATE 9-23-1993 APP EDM DATE 4-9-2007

NOTES:

1. XX DEPENDS ON SPECIFIC REQUIREMENT
2. DRAWING IS NOT SHOWN TO SCALE.

MODEL	REGISTER	BEARING	PROPELLER	LINER	CABLE	LINER STOP	U-BOLT	GASKET	TEMPLATE
M0	R1104-XX	B0600-XX	PT104-XX	6.75"	D0103-00	D0370-10	T0754-00 (2)	T0384-00	10112-01

PLEASE HAVE THE METER SERIAL NUMBER WHEN ORDERING REPLACEMENT PARTS

3-PIECE SUPPORT REPLACEMENT COMPONENTS

MODEL	LINER	CABLE	LINER STOP
M0	5.31"	D0066-00	D0370-00

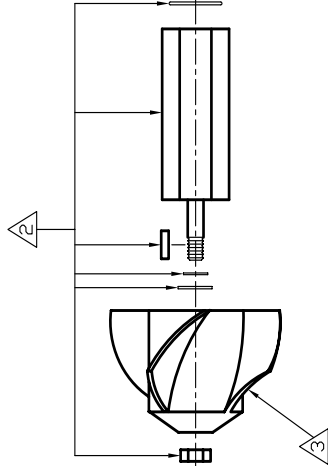
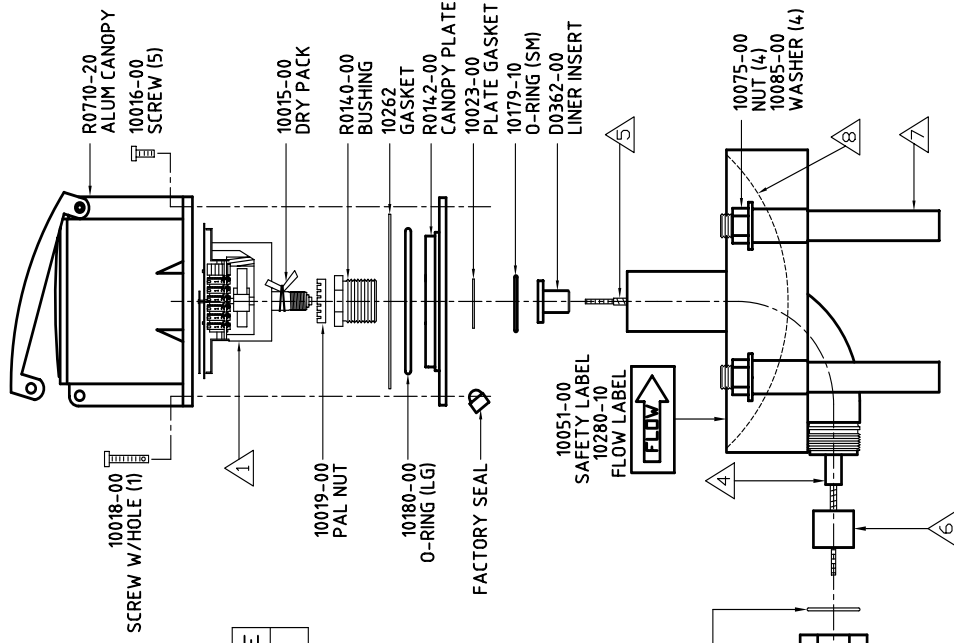

THIS DOCUMENT CONTAINS PROPRIETARY INFORMATION AND MAY NOT BE DISCLOSED TO OTHERS FOR ANY PURPOSE, NOR USED FOR MANUFACTURING PURPOSES WITHOUT WRITTEN PERMISSION FROM MCCROMETER, INC.

REV 5 4-9-2007 JMC

Page 1 of 1

MW/QW500 MG900 MT900 MW900



DESC

2", 2-1/2", & 3" TOP PLATE METERS CS & S304

FILE: 24517-11-06.dwg

DATE 4-9-2007

APP EDM

DATE 10-6-1993

BY CEH

NOTES:

1. XX DEPENDS ON SPECIFIC REQUIREMENT
2. DRAWING IS NOT SHOWN TO SCALE.

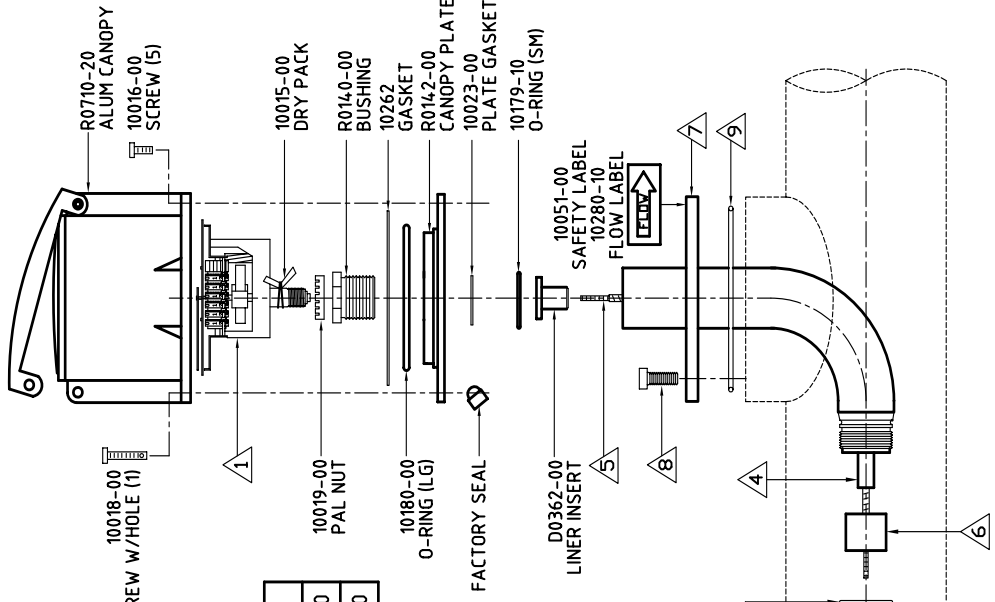

MODEL	REGISTER	BEARING	PROPELLER	LINER	CABLE	LINER STOP	ELL-ASSY	BOLT (6)	O-RING
MW MG MT MW	R1103-XX	B0700-XX	P0103-XX	6.75"	D0103-00	D0370-10	L0202-00	10049-10	10240-00
QW500	R1103-XX	B0700-XX	P0203-XX	6.75"	D0103-00	D0370-10	L0202-00	10049-10	10240-00

PLEASE HAVE THE METER SERIAL NUMBER WHEN ORDERING REPLACEMENT PARTS

3-PIECE SUPPORT REPLACEMENT COMPONENTS - ALL MODELS

NOMINAL SIZE	LINER	CABLE	LINER STOP	ELL-ASSY
2", 2-1/2", 3"	5.31"	D0066-00	D0370-00	L0203-10

MW500 MW600 MG/MW900 MT904 MT906



DESC 4" THRU 24" TOP PLATE METERS

FILE: 24517-11-07.dwg

BY CEH DATE 9-23-1993 APP EDM DATE 6-9-2007

NOTES:

- 1. XX DEPENDS ON SPECIFIC REQUIREMENT
- 2. DRAWING IS NOT SHOWN TO SCALE.

SIZE	REGISTER	BEARING	PROPELLER	LINER	CABLE	ELL-ASSY	BOLT	O-RING
4"	R1104-XX	B0600-XX	P0104-XX	D0304-00	D0104-00	L0204-10	10103-00 (6)	T0390-00
6"	R1106-XX	B0100-XX	P0106-XX	D0304-00	D0104-00	L0205-10	10103-00 (8)	T0390-10
8"	R1108-XX	B0100-XX	P0108-XX	D0303-00	D0122-00	L0206-10	10103-00 (8)	T0390-10
10"	R1110-XX	B0100-XX	P0110-XX	D0313-00	D0123-00	L0207-10	10050-00 (12)	T0399-10
12"	R1112-XX	B0100-XX	P0112-XX	D0306-00	D0106-00	L0208-10	10050-00 (12)	T0399-10
14"	R1114-XX	B0100-XX	P0112-XX	D0306-00	D0106-00	L0209-10	10050-00 (12)	T0399-10
16"	R1116-XX	B0100-XX	P0112-XX	D0307-00	D0107-00	L0210-10	10050-00 (12)	T0399-10
18"	R1118-XX	B1500-XX	P0116-XX	D0307-00	D0107-00	L0211-10	10099-00 (16)	T0399-11
20"	R1120-XX	B1500-XX	P0116-XX	D0308-00	D0108-00	L0212-10	10099-00 (16)	T0399-11
24"	R1124-XX	B1500-XX	P0116-XX	D0309-00	D0109-00	L0213-10	10099-00 (16)	T0399-11

PLEASE HAVE THE METER SERIAL NUMBER WHEN ORDERING REPLACEMENT PARTS

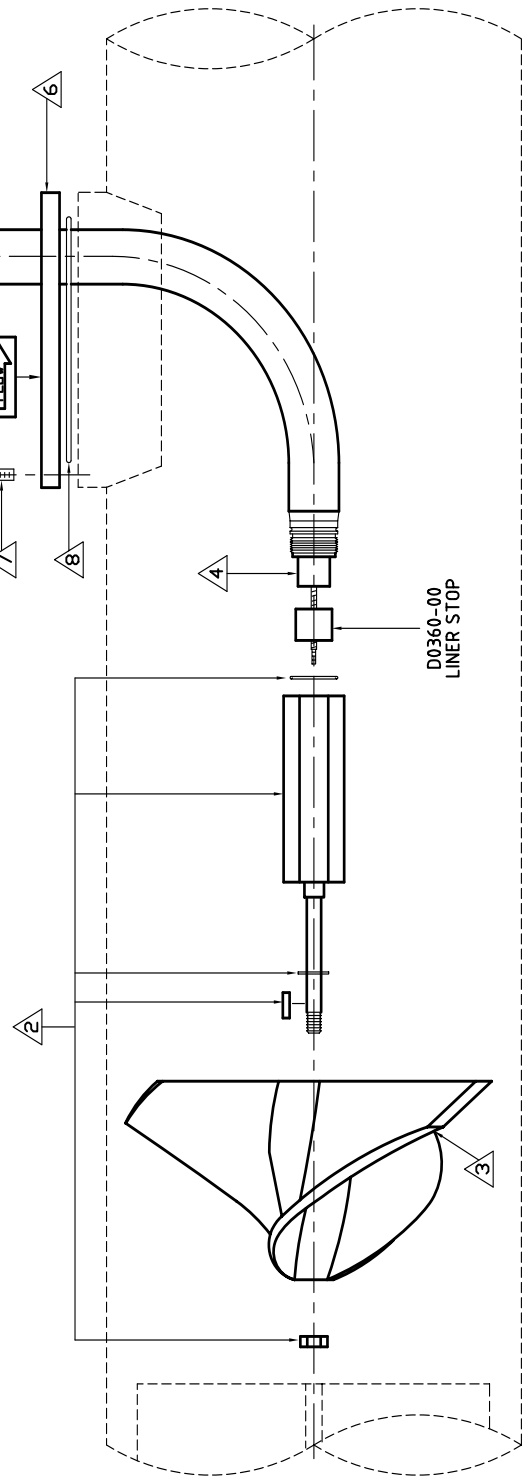
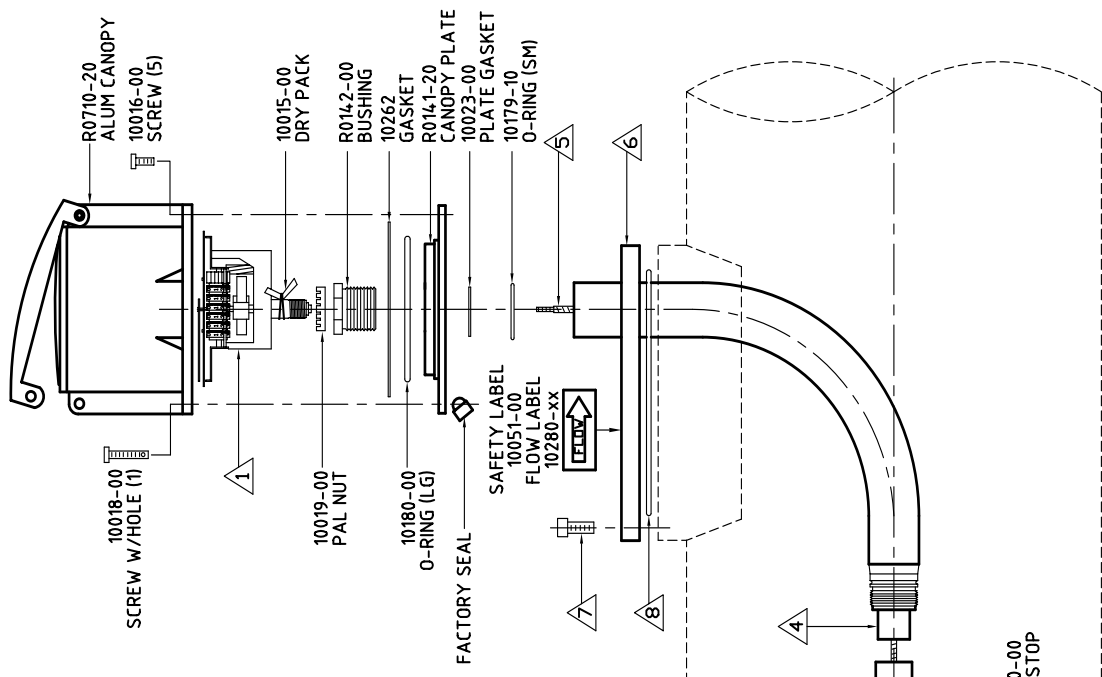

THIS DOCUMENT CONTAINS PROPRIETARY INFORMATION AND MAY NOT BE DISCLOSED TO OTHERS FOR ANY PURPOSE, NOR USED FOR MANUFACTURING PURPOSES WITHOUT WRITTEN PERMISSION FROM MCCROMETER, INC.

REV 4 4-9-2007 JMC

Page 1 of 1

QW500



4" THRU 36" TOP PLATE METERS S304

DESC

FILE: 24517-11-09.dwg

BY CEH DATE 9-28-1993 APP EDM DATE 4-10-2007

NOTES:

- 1. XX DEPENDS ON SPECIFIC REQUIREMENT
- 2. DRAWING IS NOT SHOWN TO SCALE.

SIZE	REGISTER	BEARING	PROPELLER	LINER	CABLE	ELL-ASSY	BOLT	O-RING
4"	R1104-XX	B0600-XX	P0204-XX	D0304-00	D0104-00	L0204-10	10103-00 (6)	T0390-11
6"	R1106-XX	B0100-XX	P0206-XX	D0304-00	D0104-00	L0205-10	10103-00 (8)	T0390-12
8"	R1108-XX	B0100-XX	P0208-XX	D0303-00	D0122-00	L0206-10	10103-00 (8)	T0390-12
10"	R1110-XX	B0100-XX	P0210-XX	D0313-00	D0123-00	L0207-10	10050-00 (12)	T0399-10
12"	R1112-XX	B0100-XX	P0112-XX	D0306-00	D0106-00	L0208-10	10050-00 (12)	T0399-10
14"	R1114-XX	B0100-XX	P0112-XX	D0306-00	D0106-00	L0209-10	10050-00 (12)	T0399-10
16"	R1116-XX	B0100-XX	P0112-XX	D0307-00	D0107-00	L0210-10	10050-00 (12)	T0399-10
18"	R1118-XX	B1500-XX	P0116-XX	D0307-00	D0107-00	L0211-10	10099-00 (16)	T0399-11
20"	R1120-XX	B1500-XX	P0116-XX	D0308-00	D0108-00	L0212-10	10099-00 (16)	T0399-11
24"	R1124-XX	B1500-XX	P0116-XX	D0309-00	D0109-00	L0213-10	10099-00 (16)	T0399-11
30"	R1130-XX	B1500-XX	P0145-XX	D0311-00	D0111-00	L0216-10	10135-00 (16)	T0399-12
36"	R1136-XX	B1500-XX	P0146-XX	D0312-00	D0112-00	L0217-10	10135-00 (16)	T0399-13

PLEASE HAVE THE METER SERIAL NUMBER WHEN ORDERING REPLACEMENT PARTS

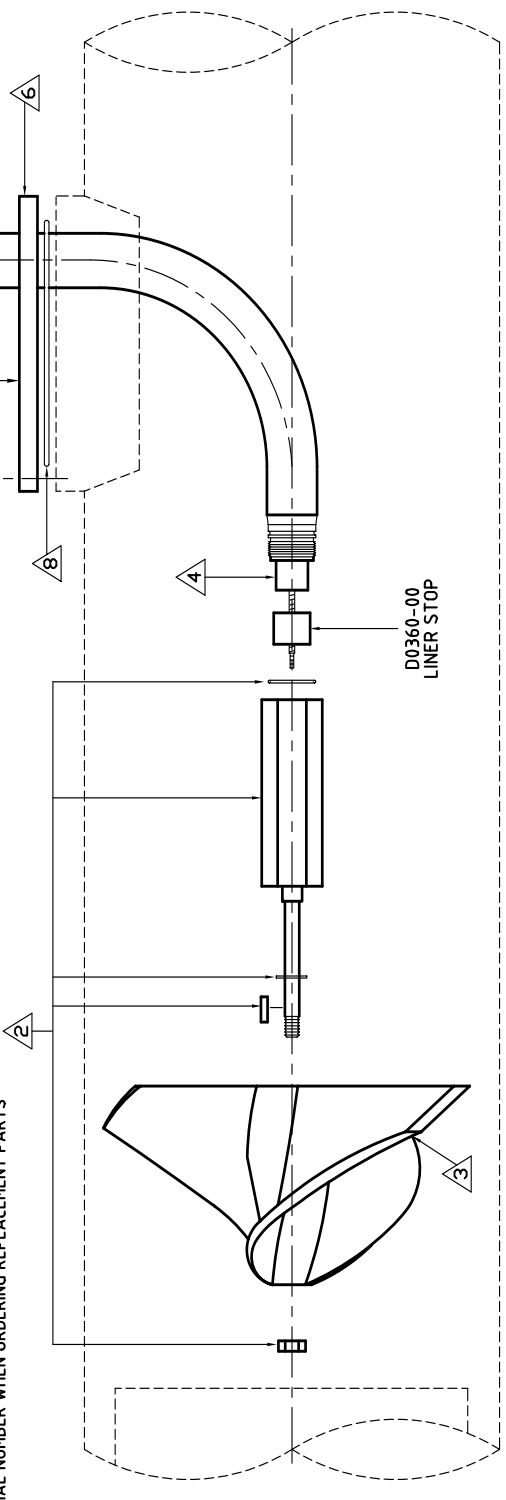
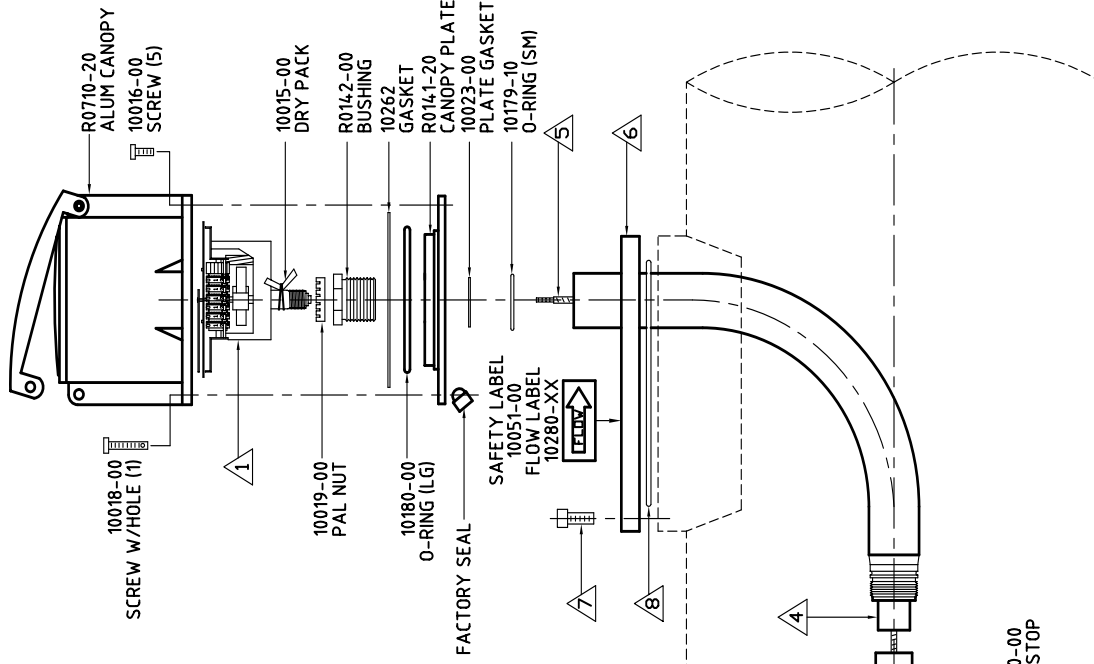

M1104

McCrometer

DESC

4" FIRE HYDRANT METER

FILE: 24517-11-10.dwg

BY CEH DATE 9-28-1993 APP EDM DATE 4-10-2007

NOTES:

- 1. XX DEPENDS ON SPECIFIC REQUIREMENT
- 2. DRAWING IS NOT SHOWN TO SCALE.

SIZE	REGISTER	BEARING	PROPELLER	LINER	CABLE	TUBE	ELL/END
4"	R1104-XX	B0700-XX	P0104-XX	D0318-00	D0066-00	T0068-00	L0155-00

PLEASE HAVE THE METER SERIAL NUMBER WHEN ORDERING REPLACEMENT PARTS

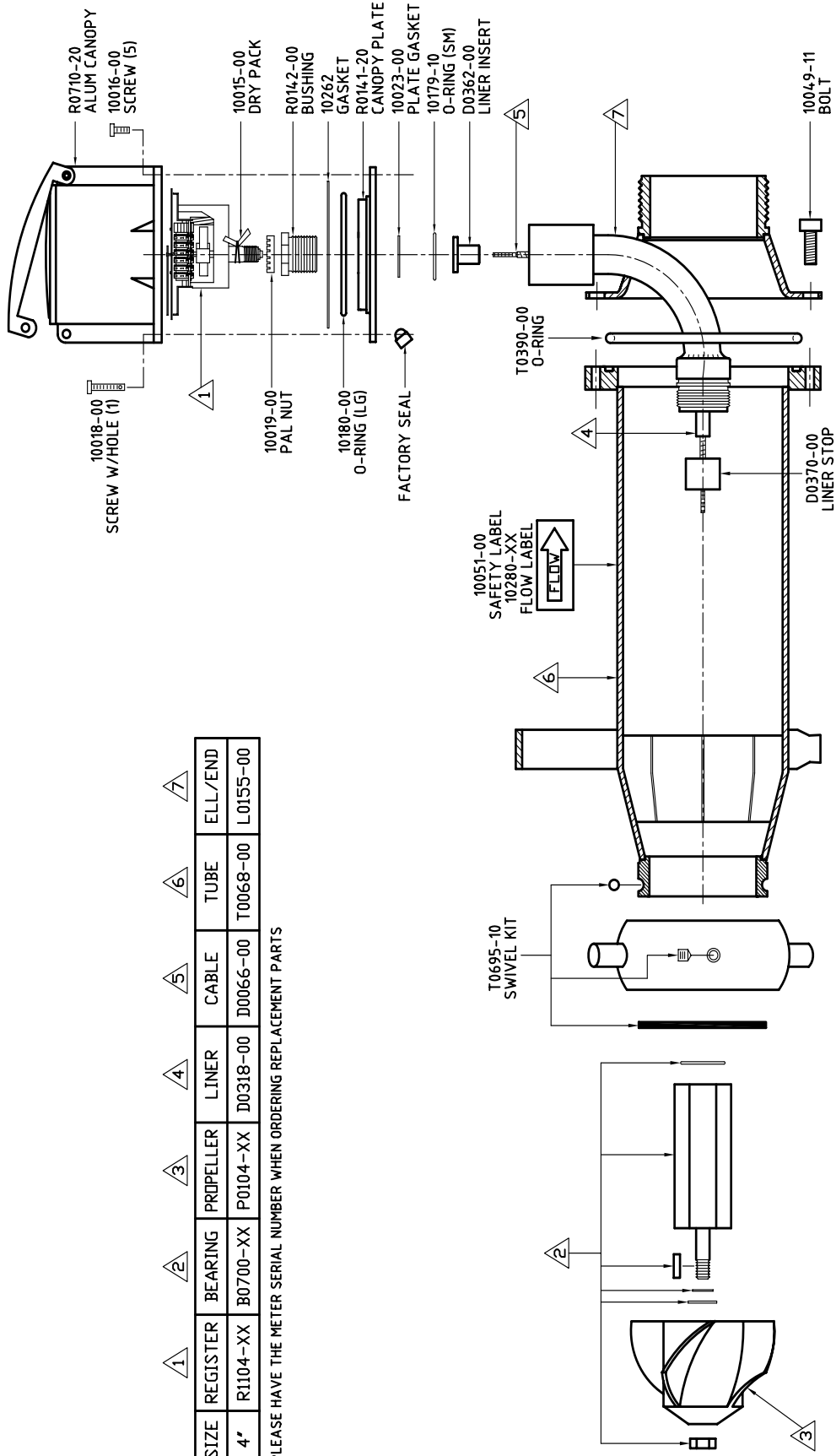

M1400



DESC 18" THRU 48" BOLT ON SADDLE METERS

FILE: MAN M1400

BY CEH DATE 9-27-1993 APP EDM DATE 4-10-2007

NOTES:

1. XX DEPENDS ON SPECIFIC REQUIREMENT
2. DRAWING IS NOT SHOWN TO SCALE.
3. CONSULT FACTORY FOR U-STRAP SIZE.

MODEL	REGISTER	BEARING	PROPELLER	LINER	CABLE	GASKET	TEMPLATE
M1418	R1118-XX	B1500-XX	P0116-XX	D0306-00	D0106-00	T0384-12	10112-10
M1420	R1120-XX	B1500-XX	P0116-XX	D0307-00	D0107-00	T0384-12	10112-10
M1422	R1122-XX	B1500-XX	P0116-XX	D0307-00	D0107-00	X8001-00	10112-10
M1424	R1124-XX	B1500-XX	P0116-XX	D0308-00	D0108-00	X8001-00	10112-10
M1426	R1126-XX	B1500-XX	P0116-XX	D0308-00	D0108-00	X8001-00	10112-10
M1428	R1128-XX	B1500-XX	P0145-XX	D0309-00	D0109-00	X8001-00	
M1430	R1130-XX	B1500-XX	P0145-XX	D0309-00	D0109-00	X8001-00	
M1432	R1132-XX	B1500-XX	P0145-XX	D0310-00	D0110-00	X8001-00	
M1436	R1136-XX	B1500-XX	P0146-XX	D0311-00	D0111-00	X8001-00	
M1442	R1142-XX	B1500-XX	P0146-XX	D0312-00	D0112-00	X8001-00	
M1448	R1148-XX	B1500-XX	P0146-XX	29'	31.19'	X8001-00	

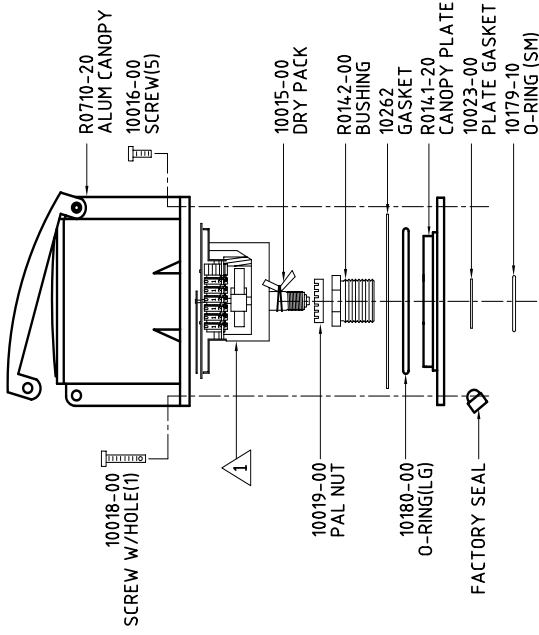

PLEASE HAVE THE METER SERIAL NUMBER WHEN ORDERING REPLACEMENT PARTS

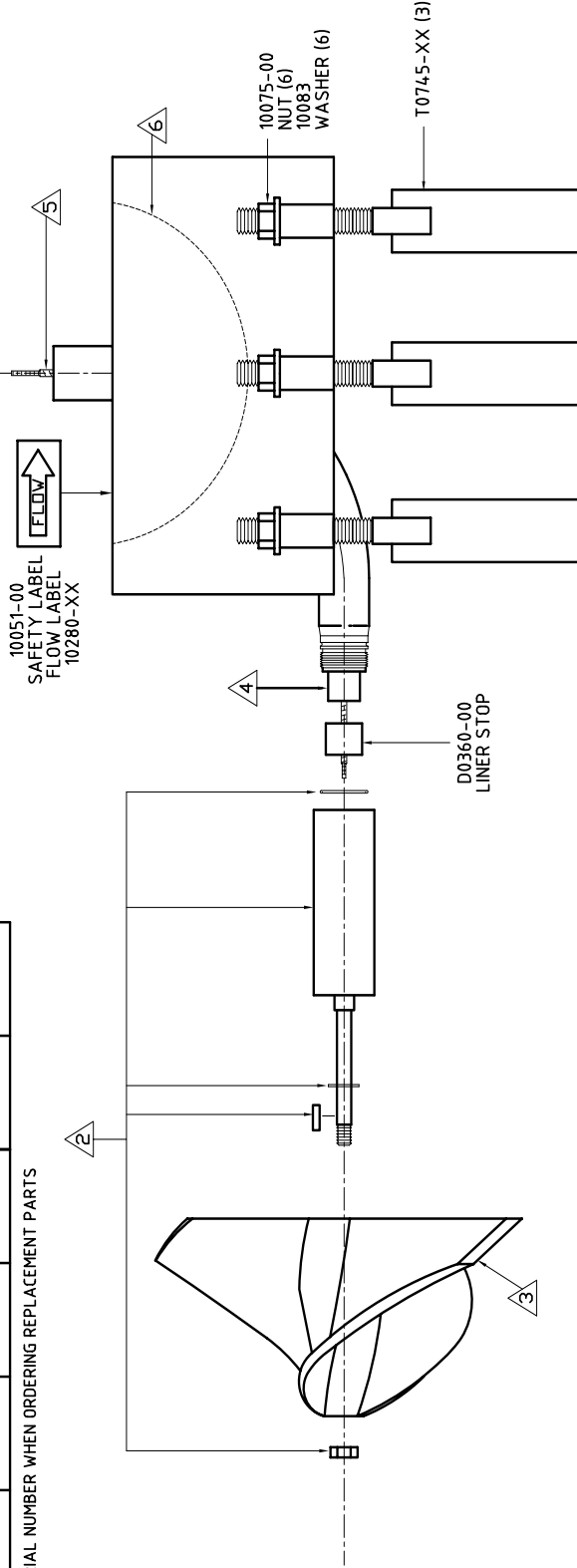

THIS DOCUMENT CONTAINS PROPRIETARY INFORMATION AND MAY NOT BE DISCLOSED TO OTHERS FOR ANY PURPOSE, NOR USED FOR MANUFACTURING PURPOSES WITHOUT WRITTEN PERMISSION FROM MCCROMETER, INC.

REV 4 4-10-2007 JMC

Page 1 of 1

M1708 THRU M1736



DESC 8" THRU 36" OPEN FLOW METERS

BY CEH DATE 10-01-1993 APP EDM DATE 4-10-2007

FILE: 24517-11-12.dwg

NOTES:

1. XX DEPENDS ON SPECIFIC REQUIREMENT
2. DRAWING IS NOT SHOWN TO SCALE.

SIZE	REGISTER	BEARING	PROPELLER	LINER	CABLE	DROP PIPE	HEIGHT
8"	R1108-XX	B0100-XX	P0108-XX	59'	D0126-00	L0775-10	5'
10"	R1110-XX	B0100-XX	P0110-XX	59'	D0126-00	L0775-10	5'
12"	R1112-XX	B0100-XX	P0112-XX	59'	D0126-00	L0775-10	5'
14"	R1114-XX	B0100-XX	P0112-XX	59'	D0126-00	L0775-10	5'
16"	R1116-XX	B0100-XX	P0112-XX	59'	D0126-00	L0775-10	5'
18"	R1118-XX	B1500-XX	P0116-XX	67.9'	D0127-00	L0776-10	6'
20"	R1120-XX	B1500-XX	P0116-XX	67.9'	D0127-00	L0776-10	6'
24"	R1124-XX	B1500-XX	P0116-XX	67.9'	D0127-00	L0776-10	6'
30"	R1130-XX	B1500-XX	P0145-XX	67.9'	D0127-00	L0776-10	6'
34"	R1134-XX	B1500-XX	P0146-XX	67.9'	D0127-00	L0776-10	6'
36"	R1136-XX	B1500-XX	P0146-XX	67.9'	D0127-00	L0776-10	6'

PLEASE HAVE THE METER SERIAL NUMBER WHEN ORDERING REPLACEMENT PARTS

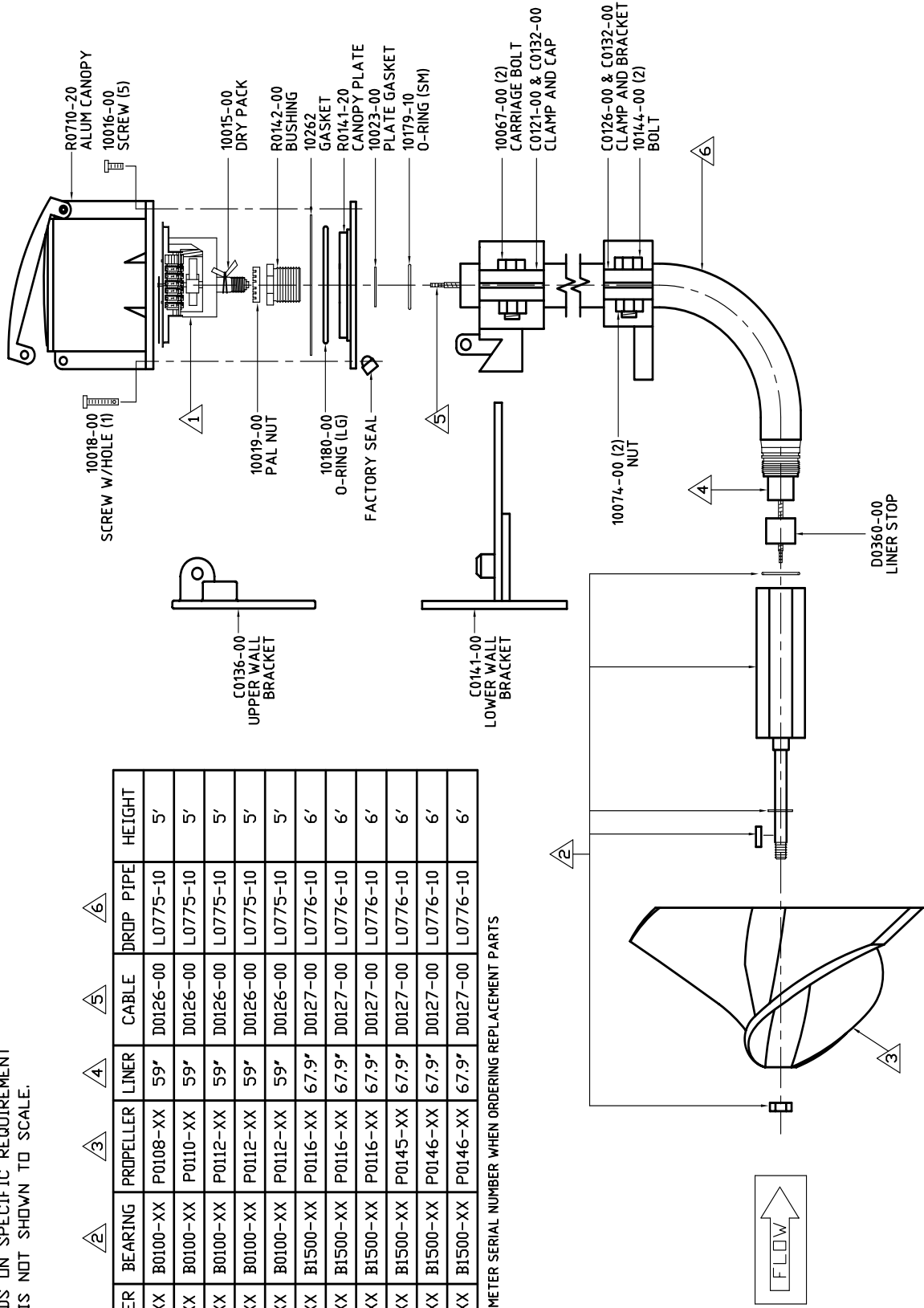

MM803 THRU MM816



DESC

8" THRU 24" DOWN-FLOW METERS

FILE: 24517-11-13.dwg

BY CEH

DATE 9-30-1993

APP EDM

DATE 4-10-2007

NOTES:

1. XX DEPENDS ON SPECIFIC REQUIREMENT
2. DRAWING IS NOT SHOWN TO SCALE.

1 2 3 4 5 6 7 8 DIMENSIONS

SIZE	REGISTER	BEARING	PROPELLER	LINER	CABLE	BOLTS	D-RING	TOP PLATE	A	B	C
3'	R1103-XX	B0700-XX	P0103-XX	9.63"	11.62"	10049-10 (6)	10152-10	L0145-20	22.50"	5"	12.25"
4'	R1104-XX	B0600-XX	P0104-XX	15.75"	18.13"	10103-00 (6)	T0390-00	L0325-30	27.88"	6.50"	16.63"
6'	R1106-XX	B0100-XX	P0106-XX	16.25"	18.63"	10103-00 (8)	T0390-10	L0326-20	29.88"	8"	18"
8'	R1108-XX	B0100-XX	P0108-XX	22"	24"	10103-00 (8)	T0390-10	L0327-10	36.38"	9"	23"
10'	R1110-XX	B0100-XX	P0110-XX	27"	29.19"	10050-00 (12)	T0399-10	L0328-30	42.38"	11"	28"
12'	R1112-XX	B0100-XX	P0112-XX	32.25"	34.63"	10050-00 (12)	T0399-11	L0328-30	48.38"	12"	33"
14'	R1114-XX	B0100-XX	P0112-XX	37.25"	39.63"	10050-00 (16)	T0399-11	L0330-20	54"	14"	38"
16'	R1116-XX	B0100-XX	P0112-XX	42.25"	44.63"	10050-00 (16)	T0399-11	L0331-20	60"	15"	43"

PLEASE HAVE THE METER SERIAL NUMBER WHEN ORDERING REPLACEMENT PARTS

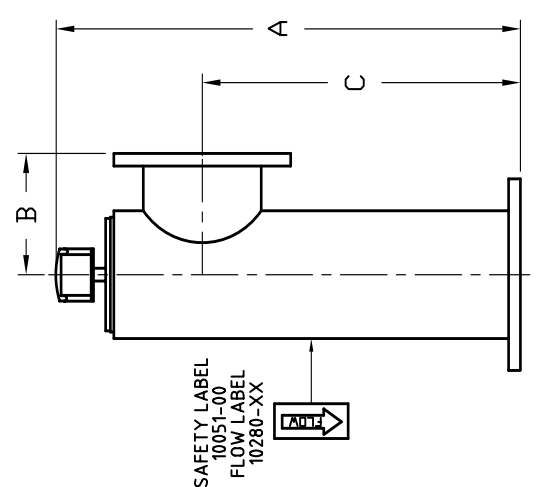
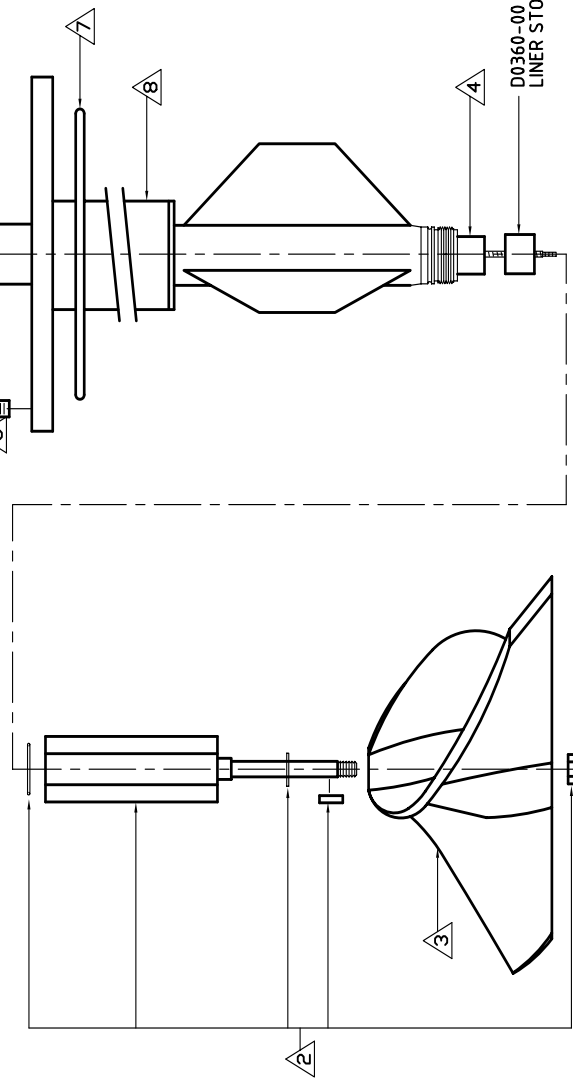
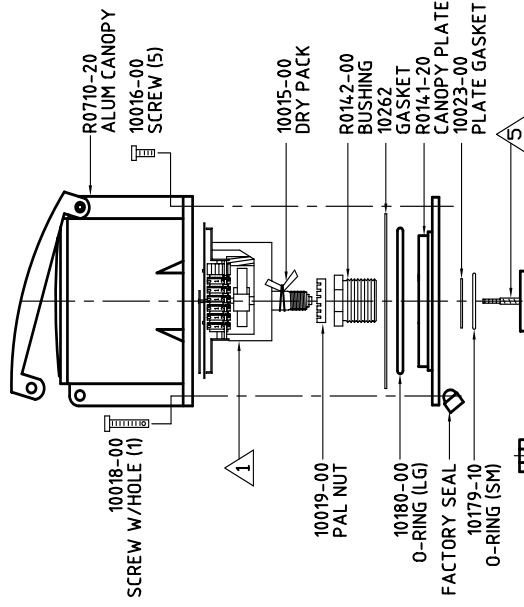

SAFETY LABEL
 10051-00
 FLOW LABEL
 10280-XX

THIS DOCUMENT CONTAINS PROPRIETARY INFORMATION AND MAY NOT BE DISCLOSED TO OTHERS FOR ANY PURPOSE, NOR USED FOR MANUFACTURING PURPOSES WITHOUT WRITTEN PERMISSION FROM MCCROMETER, INC.

REV 3 4-10-2007 JMC

Page 1 of 1

OTHER McCROMETER PRODUCTS INCLUDE:

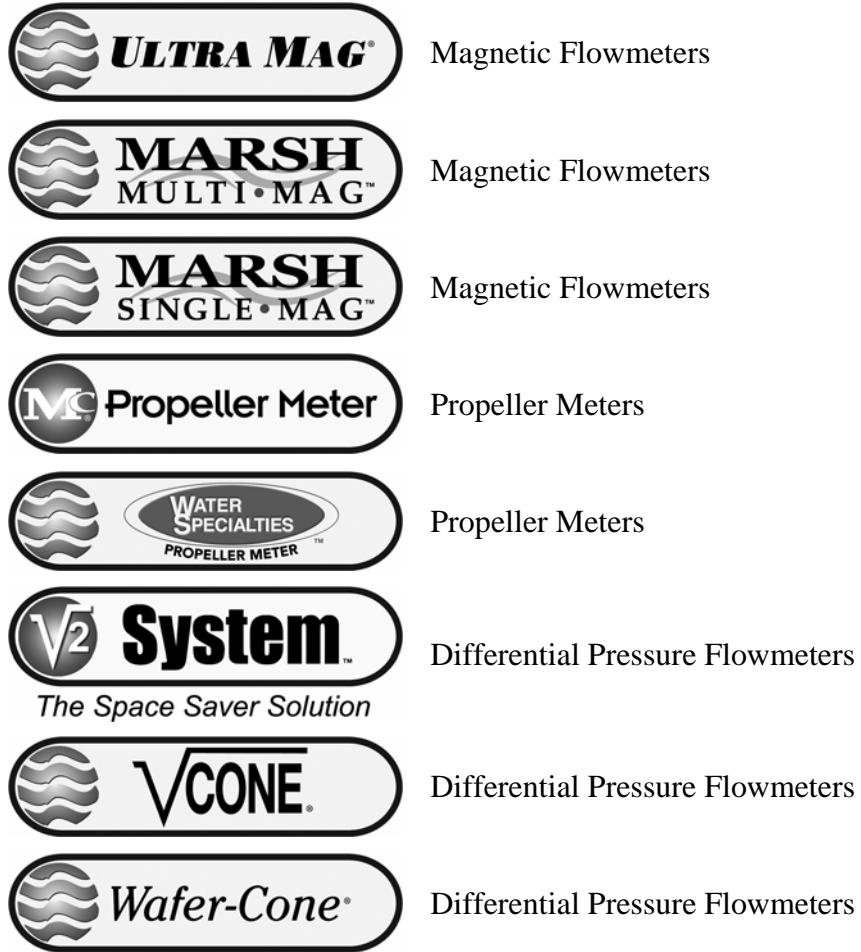

Electronic Instrumentation for Remote Display and Control

FOR MORE INFORMATION CONTACT:

Represented by:



3255 W. Stetson Avenue, Hemet, CA 92545
Tel: (951) 652-6811 Fax: (951) 652-3078
Web Site: www.mccrometer.com
Hours: 8 a.m. – 4 p.m. PST, Monday-Friday