

MODEL MT100

THREADED END FLOWMETER

DESCRIPTION

The Model MT100 is manufactured to comply with the applicable provisions of the American Water Works Association Standard No. C704-92 and latest revisions for propeller type flowmeters. The threaded ends of the MT100 allow it to be directly coupled into an existing pipeline. The carbon steel flow tube has a fusion-bonded epoxy coating offering excellent corrosion protection. As with all McCrometer propeller flowmeters, standard features include a magnetically coupled drive, instantaneous flowrate indicator and straight-reading, six-digit totalizer.

Impellers are manufactured of high-impact plastic, capable of retaining their shape and accuracy over the life of the meter. Each impeller is individually calibrated at the factory to accommodate the use of any standard McCrometer register, and since no change gears are used, the MT100 can be field-serviced without the need for factory recalibration. Factory lubricated, stainless steel bearings

are used to support the impeller shaft. The shielded bearing design limits the entry of materials and fluids into the bearing chamber providing maximum bearing protection.

An instantaneous flowrate indicator is standard and available in gallons per minute, cubic feet per second, liters per second and other units. The register is driven by a flexible steel cable encased within a protective self-lubricating liner. The register housing protects both the register and cable drive system from moisture while allowing clear reading of the flowrate indicator and totalizer.

INSTALLATION

Standard installation is horizontal mount. If the meter is to be mounted in the vertical position, please advise the factory. A straight run of full pipe the length of five diameters ahead and one diameter behind the meter is the minimum normally recommended.

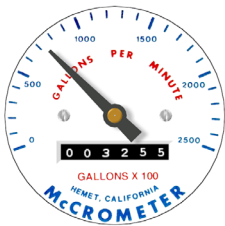

The McCrometer Propeller flowmeter comes with a standard instantaneous flowrate indicator and straight-reading totalizer. An optional electronic register is also available. *Typical face plates.*

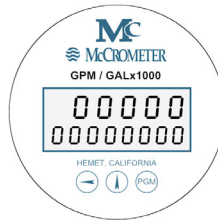

APPLICATIONS

The McCrometer propeller meter is the most widely used flowmeter for municipal and wastewater treatment applications as well as agricultural and turf irrigation measurement. Typical applications include:

- Water and wastewater management
- Truck loading and discharge
- Sprinkler irrigation systems
- Drip irrigation systems
- Golf course and park water management
- Commercial nurseries



THREADED END FLOWMETER MODEL MT100

SPECIFICATIONS

PERFORMANCE

ACCURACY/REPEATABILITY: ±2% of reading guaranteed throughout full range; ±1% over reduced range; Repeatability 0.25% or better

MAXIMUM TEMPERATURE: (Standard Construction) 160°F constant

PRESSURE RATING: 150 psi

MATERIALS

BEARING ASSEMBLY: Impeller shaft is 316 stainless steel. Ball bearings are 440C stainless steel.

MAGNETS: (Permanent type) Cast or sintered Alnico

BEARING HOUSING: Brass; Stainless Steel optional

REGISTER: An instantaneous flowrate indicator and six-digit straight-reading totalizer are standard. The register is hermetically sealed within a die cast aluminum case. This protective housing includes a domed acrylic lens and hinged lens cover with locking hasp.

IMPELLER: Impellers are manufactured of high-impact plastic, retaining their shape and accuracy over the life of the meter. High temperature impeller is optional.

FLOW TUBE: Fusion-bonded epoxy-coated carbon steel

OPTIONS

- Forward/reverse flow measurement
- Register extensions
- All stainless steel construction
- High temperature construction
- "Over Run" bearing assembly for higher than normal flowrates
- Electronic Propeller meter available in all sizes of this model
- A complete line of recording/control instrumentation can be driven from this flowmeter
- Certified calibration test results

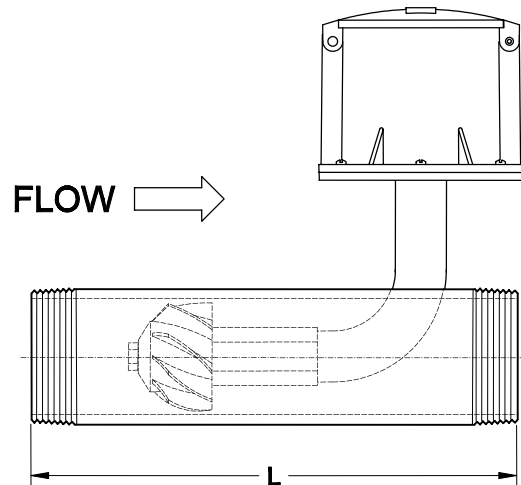
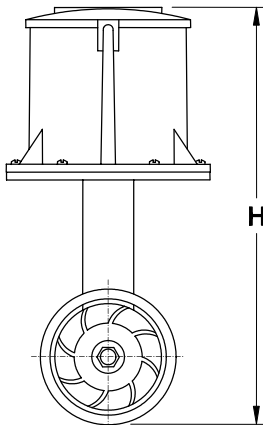

McCrometer reserves the right to change design or specifications without notice.

MT100	DIMENSIONS			
Meter Size	2"	2 1/2"	3"	4"
Maximum Flow U.S. GPM	250	250	250	600
Minimum Flow U.S. GPM	35	35	35	50
Approx. Head Loss in Inches at Max. Flow	29.50	29.50	29.50	23
Approx. Shipping Weight-lbs.	* SEE SPECIAL NOTE		17	40
H (inches)			10	13
L (inches)			13	20
O.D. of Meter Tube			3.50	4.500

Larger flowmeters on special order.

*SPECIAL NOTE — Reducing fittings are supplied to adapt the 3-inch model to smaller line sizes.

FOR MORE INFORMATION CONTACT:



3255 West Stetson Avenue
Hemet CA 92545 USA
909-652-6811 / FAX 909-652-3078
e-mail: info@mccrometer.com
Web Site: <http://www.mccrometer.com>